



Service Manual

Models: GDN16BE-K5EBA1A
GDN20BE-K5EBA1A
GDN20BE-K5EBA2A
GDN24BE-K5EBA2A
(Refrigerant R290)

Gree Climat

GREE ELECTRIC APPLIANCES, INC. OF ZHUHAI

Table of Contents

Part I : Technical Information	12
1.Summary	12
2.Specifications	13
3.Outline Dimension Diagram	17
4.Refrigerant System Diagram	19
5.Electrical Part	20
5.1 Wiring Diagram.....	20
5.2 PCB Printed Diagram.....	22
6.Function and Control	25
6.1 Control Panel Instruction	25
6.2 Introduction of Basic Mode Function.....	29
6.3 GREE+ App Operation Manual.....	30
6.4 Ewpe Smart App Operation Manual	31
Part II : Maintenance	32
7.Notes Maintenance	32
8.Operation and maintenance	34
8.1 Drainage Option	34
8.2 Clean and Maintenance	34
8.3 Check Before Use-season.....	35
8.4 Care After Use-season.....	35
8.5 Long-time Storage	35
9.Maintenance	36
9.1 Safety Principle of Maintenance	36
9.2 Preparation before Maintenance	36
9.3 Maintenance Cautions.....	37
9.4 Error Code	39

9.5 Malfunction Detection Flowchart	40
9.6 Maintenance Method for Common Malfunction	44
10.Exploded View and Parts List	46
11.Removal Procedure	50
Appendix:	60
Appendix 1: Reference Sheet of Celsius and Fahrenheit	60
Appendix 2: Resistance Table of Temperature Sensor	61
Appendix 3: Resistance Value Table of Humidity Sensor	66

Gree Climat

Abbreviations Used Within this Manual:

Abbreviation	Clear Words
OFDN	Oxygen free and dry nitrogen
PPE	Personnel protective equipment
LFL	Lower flammability level
UFL	Upper flammability level
HC	Hydrocarbon

INTRODUCTION

ATTENTION



Please read this manual carefully before installing and operating the GREE Hydrocarbon Air- Conditioner unit.

Careless installation and operation could cause severe injuries to operators, workers and damage to the air-conditioner unit itself.

Keep this manual in a location for easy access as it is needed for reference during installation, maintenance, service and operation of the unit.

This manual does not cover all aspects of installation, maintenance and service of the chiller units; if additional information is needed, contact the GREE Customer Service or Sales Office.

General Information

Warning and cautions appear at appropriate locations throughout this manual book.

Notices

General Safety Instructions

Please pay careful attention to these safety instructions, to avoid risks to people and property. Before starting work on maintenance read this manual thoroughly and pay particular attention to the relevant chapters.

Regardless of further requirements of the country, in which the equipment will be installed: assembly, first start up, technical service, maintenance and repair and as well as dismantling and disposal have to be carried out by authorised personnel only.

During every operation strictly follow the instructions within this manual. Pay attention to the specific rules of air conditioning, electrics and refrigerant handling of the country within which the equipment is installed.

Key sections and/or sentences are highlighted with specific icons and symbols to the right side of the page. Please pay particular attention to this information.

The Symbols Used in this Manual are as Follows

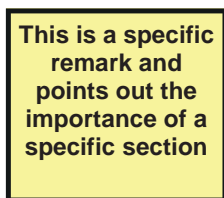

Information window highlighting important content of the specific section or additional information to consider.



This sign will indicate that you are handling a flammable substance and the surrounding environment can possibly contain it.



This is a general warning sign.



The Label is used to indicate that the flammable refrigerant is present within the application and service equipment.



Images that indicate something what you should strictly avoid.



Specific bans!



Specific commandments!



Instructions for first aid!



Fire protection!



Carefully read the instructions!

Working on components with safety-relevant functions jeopardise the safe operation of the installation. In case it is necessary to replace components, only use approved parts from GREE Electric, the Original Equipment Manufacturer(OEM) or Gree released or authorised components. The system contains the refrigerant R-290 (propane). This condition requires special safety precautions to be observed. Maintenance for the system is strictly prohibited. At the installation site, no matter what kind of activities are executed, smoking is strictly prohibited! Likewise, ensure the installation site is well ventilated. For further details as far as it concerns the handling of the refrigerant R-290 (propane) .

ONLY original GREE (OEM) spare-parts are permitted for Service and Repair!



The Symbols Used in this Manual are as Follows

Electric operations (installation, repair, modification, maintenance, adjustment) have to be fulfilled by trained and authorised personnel only. When dealing with electrical issues, the specific rules of the country within which the equipment is installed must be followed, in addition to the instructions within this manual.

Proceed according the manuals Instructions!

When working on the equipment or parts of it, the system has to be deenergised (by master switch, circuit breaker or separate cut-out) and made safe against restart of the system. Do not reconnect the system to the electric circuit until all work is done and all connections are tested. If handled unsafely or unprofessionally, severe electric shocks can occur. Consider the wiring diagram and follow the instructions of this manual very carefully whilst working on electrical parts. Wrong connections or incorrect grounding may lead to severe injuries and mortal danger.

Ground the system according to the particular requirements of the country within which the equipment is installed. Connect all the wires properly and durably. Loose cables may lead to overheating or fire .



Minimum Room Size

HC R290 is a flammable refrigerant and can form explosive mixtures in low concentrations. To minimise the risk of fire or explosion, the system must be installed in a room with a minimum floor area.

Pay attention to the room size for indoor unit installation!

For specific information refer **page XXX** of this manual.

Unless there are further requirements, standards and legislation of the country within which the equipment is installed may apply. Any technicians that works on GREE hydrocarbon air- conditioners must be competent in the safe handling of flammable refrigerants, in addition to being in possession of knowledge and skills to maintain best refrigeration installation and servicing practices.

There are already training activities in place for engineers, technicians and sales staff to provide professional knowledge and skills for the handling of HC refrigerants and refrigeration systems operating with HCs.

Get your Best Practices knowledge and skills update for HC refrigerants and be certificated for these jobs!

Get trained and have your “HC Refrigeration Professional” certification!



Basics in RAC

Knowledge of the basic SI standard units for temperature, pressure, mass, density, energy.

Understanding of the basic theory of refrigeration systems including the functions of the main components in the system (compressor, evaporator, condenser, thermostatic expansion valves).

Understanding how to read a refrigerant flow chart and an electrical circuit diagram.

The determination of non condensable gases in the refrigeration system and how to eliminate them.

The importance of the use of oxygen free dry nitrogen (OFDN) for system flushing, leak test and strength test.

The elimination of humidity from the refrigeration system and how to recover or vent HC refrigerant from a system.

Usage of tables and diagrams (log p/h diagram, saturation tables of a refrigerant, diagram of a single compression refrigeration cycle) and interpretation of these tables and diagrams.

Knowledge of the basic operation of the following components in a refrigeration system and their role and importance for refrigerant leakage prevention and identification:

- Temperature and pressure controls
- Sight class and moisture indicators
- Defrost controls, reverse cycle operation
- System protectors
- Measuring devices such as the pressure gauge manifold
- Thermometer
- Leak detector
- Refrigerant charging devices
- Vacuum pump
- Oxygen free dry nitrogen cylinder and pressure regulator

Fault finding – analysis and repair.

- Knowledge of flammable refrigerants
- Risk analysis for the application of flammable refrigerant and properties of flammable refrigerants
- Electrical circuit assessment and repair

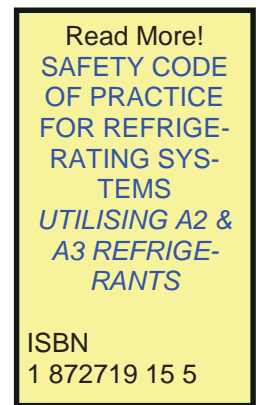

Checks before putting in operation, after a long period of nonuse, after maintenance or repair intervention or during operation.

Carry out a pressure and leak test to check the strength and the tightness of the system.

Usage of a vacuum pump.

Evacuation of the system to remove air and moisture according to standard practice.



Checks for Leakage

Knowledge of potential leakage points of refrigeration, air-conditioning and heat pump equipment. Making a visual and manual inspection of the whole system.

Carry out a check for leakage of the system using an indirect method and/or one of the direct methods.

Direct leak detection methods:

1. Fixed leakage detection systems
2. Portable electronic gas detectors
3. Ultraviolet (UV) indication fluids
4. Weak soapy water solution (bubble test) also in combination with OFDN
5. New installation tightness test for leakage detection procedure e.g. H2/N2
6. Operational system tightness test for leakage detection procedure

Indirect refrigerant detection methods:

1. Visual
2. Manual checks

HC R290 Refrigerant Issues

Please notice that the unit is filled with propane. Details to this refrigerant are found in chapter "refrigerant". Propane is highly flammable and leads to explosion under certain conditions. Inappropriate treatment of the unit involves the risk of severe damages of people and material.

Basics

HC R-290 (propane) is an odourless and colourless gas of the group of hydrocarbons. HC R-290 is heavier than air and at high concentrations can cause narcotic effects and eventually asphyxiation.

R-290 is highly flammable within the range of 2,1% and 9,5% by volume, or 38 g/m³ to 170 g/m³ in air. The auto-ignition temperature is about 470°C.

Since R-290 is an odourless and colourless gas, it is difficult to perceive that it is present (as with most other refrigerants).

Propane is often used as a fuel such as for heating or barbecues. However, for use on refrigeration systems, fuel-grade propane is not suitable since it contains high levels of impurities, which would damage the refrigeration system and may not provide the desired refrigerating capacity or efficiency.



HC R-290 refrigerant has a high grade of purity.

Propane as a cooking gas is not useful for refrigeration purpose!

The structural formula of HC R-290 (propane)

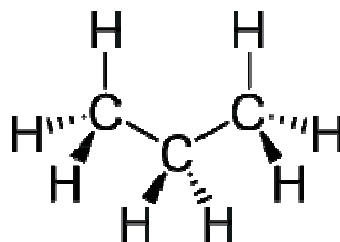

Important Refrigerant Properties and Parameters:

Molecular formula	C ₃ H ₈
Melting point [°C]	-188
Boiling point under atmospheric pressure [°C]	-42
Molar mass [g mol ⁻¹]	44,10
Critical temperature [°C]	96,8
Critical pressure [bar]	42
Practical limit [g/m ³]	8
Lower flammability level LFL [g/m ³]	38
Lower flammability level LFL [%]	2,1
Upper flammability level UFL [g/m ³]	171
Upper flammability level UFL [%]	9,5
Ignition temperature [°C]	470

Read More!

Guidelines for the safe use of hydrocarbon refrigerants

GIZ—PROKLIMA

<http://www.gtz.de/proklima>

Flammability

Three components are needed simultaneously for causing fire:

1. Oxygen
2. Ignition source
3. The flammable concentration of HC

For ignition, the concentration of HC in air has to be between the lower and upper flammable limits. If the concentration is below the lower flammability limit (LFL) of about 2% by volume in air, there is not enough HC for combustion. If the concentration is above the upper flammability limit (UFL) of about 10% there is insufficient oxygen for combustion.

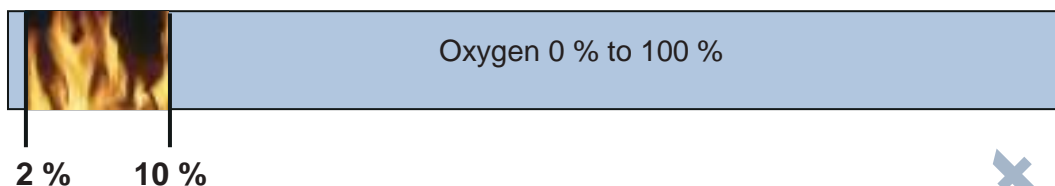

2 % 10 %
HC R-290
Refrigerant

By way of illustration please compare to the schematic view:

Possible ignition sources are:

1. A flame, for example from brazing torch, halide torch leak lamp, match or lighter, cigarette
2. A spark from an electrical component
3. Static electricity
4. Hot surfaces

Safety Data

Hazard Identification

- Extremely flammable (F+).
- Readily forms an explosive air-vapour mixture at ambient temperatures.
- Vapour is heavier than air and may travel to remote sources of ignition (e.g. along drainage systems, into basements etc).
- Liquid releases generate large volumes of flammable vapour (approx 250:1)
- Cold burns (frostbite) will result from skin / eye contact with liquid.
- Liquid release or vapour pressure jets present a risk of serious damage to the eyes.
- Abuse involving inhalation of high concentrations of vapour, even for short periods, which can produce unconsciousness or may prove fatal. Inhalation may cause irritation to the nose and throat, headache, nausea, vomiting, dizziness and drowsiness. In poorly ventilated areas unconsciousness or asphyxiation may result.



To ignite HC R-290, three (3) components must exist at the same time at work area to cause the refrigerant burning!



1 kg of liquid HC R-290 refrigerant creates about 250 litres of gas

Beside the flammability, most other safety properties are similar to other refrigerants!

Rely always on best service practices in refrigeration!

First Aid Measures

Inhalation:

Remove the affected person to fresh air. If breathing has stopped, administer artificial respiration. Give external cardiac massage if necessary. If the person is breathing but unconscious, place them in the recovery position. Obtain medical assistance immediately.

Skin:

In case of cold burns: flush with water to normalize temperature. Cover the burns with sterile dressings. Do not use ointments or powders. Obtain medical assistance immediately.

Eyes:

Cold burns should be flushed with water to normalise temperature, cover the eye with a sterile dressing and obtain medical assistance immediately.

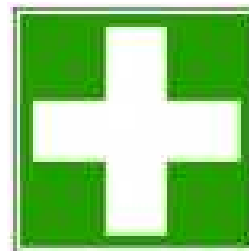

Fire Fighting Measures

HC R-290 is delivered, stored, and used at temperatures above their flash point. Avoid all naked flames, sparks, cigarettes etc.

- In case of fire, immediately alert fire brigade
- Ensure an escape path is always available from any fire
- If gas has ignited do not attempt to extinguish but stop gas flow and allow to burn out.
- Use water spray to cool heat-exposed containers, and to protect surrounding areas and personnel effecting the shut off
- Every precaution must be taken to keep containers cool to avoid the possibility of a boiling liquid expanding vapour explosion (BLEVE)

Extinguishing Media:

In case of a large fire:

Release must be stopped and container cooled by water spray.

Water mist should be used to assist approach to the source of the fire.

Large fires should only be handled by Fire Brigade.

DO NOT USE WATER JET

Small fire:

Use dry powder extinguisher



DO NOT USE WATER JET

Special protective equipment for fire fighters:

In confined spaces use self-contained breathing apparatus

Hazardous combustion products:

Incomplete combustion may form carbon monoxide.



Accidental Release Measures

Immediate emergency action:

- Clear people away from the area to a safe place
- Do not operate electrical equipment unless "Ex"-rated
- Summon the emergency services
- Treat or refer casualties if necessary

Further actions:

- Stop release
- Use dry powder or carbon dioxide extinguishers
- Cool containers exposed to fire by using water / mist spray.

Further action (when release is made safe):

- Extinguish all naked lights – avoid creating sparks
- Position fire fighting equipment
- Cover drains and disperse vapour with water spray.

Note: vapour may collect in confined spaces.

Accidental Release Measures

Due to the flammability of R-290 and the risk of fire or explosion during servicing, special safety rules must be followed during operation. In order to avoid damage for people and property, particular requirements are listed hereafter.

Before servicing the unit, the surrounding area where the work will be done must be clear of safety hazards to ensure safe working. Nevertheless it is required to carry out a risk assessment in order to minimise the risk of ignition of R-290.



The following safety measures must be followed:

1. Any employees and other present persons must be informed about the service and the way the service is done, first.
2. It is recommended to isolate the working environment in order to keep out any unauthorised personnel.
3. It is useful to set up signs such as „no smoking“ or „access denied“.
4. It is prohibited to store any combustible goods within the working environment.
5. Within two (2) metres radius, ignition sources are not allowed in the working area.
6. Fire extinguisher (dry powder) must be easily accessible at any time.
7. During service work, proper ventilation of the environment must be ensured.

Pressure—Temperature Chart

HC Refrigerant R-290							
Temperature		Absolute pressure			Gauge pressure		
°C	°F	kPa	bar	PSI	kPa(g)	bar(g)	PSI(g)
-40	-40	111,12	1,11	16,12	11,12	0,11	1,61
-39	-38,2	116,00	1,16	16,83	16,00	0,16	2,32
-38	-36,4	121,05	1,21	17,56	21,05	0,21	3,05
-37	-34,6	126,27	1,26	18,31	26,27	0,26	3,81
-36	-32,8	131,66	1,32	19,10	31,66	0,32	4,59
-35	-31	137,23	1,37	19,90	37,23	0,37	5,40
-34	-29,2	142,97	1,43	20,74	42,97	0,43	6,23
-33	-27,4	148,90	1,49	21,60	48,90	0,49	7,09
-32	-25,6	155,02	1,55	22,48	55,02	0,55	7,98
-31	-23,8	161,33	1,61	23,40	61,33	0,61	8,89
-30	-22	167,83	1,68	24,34	67,83	0,68	9,84
-29	-20,2	174,54	1,75	25,31	74,54	0,75	10,81
-28	-18,4	181,44	1,81	26,32	81,44	0,81	11,81
-27	-16,6	188,56	1,89	27,35	88,56	0,89	12,84
-26	-14,8	195,89	1,96	28,41	95,89	0,96	13,91
-25	-13	203,43	2,03	29,51	103,43	1,03	15,00
-24	-11,2	211,19	2,11	30,63	111,19	1,11	16,13
-23	-9,4	219,18	2,19	31,79	119,18	1,19	17,29
-22	-7,6	227,39	2,27	32,98	127,39	1,27	18,48
-21	-5,8	235,84	2,36	34,21	135,84	1,36	19,70
-20	-4	244,52	2,45	35,46	144,52	1,45	20,96
-19	-2,2	253,44	2,53	36,76	153,44	1,53	22,26
-18	-0,4	262,61	2,63	38,09	162,61	1,63	23,58
-17	1,4	272,03	2,72	39,45	172,03	1,72	24,95
-16	3,2	281,70	2,82	40,86	181,70	1,82	26,35
-15	5	291,62	2,92	42,30	191,62	1,92	27,79
-14	6,8	301,81	3,02	43,78	201,81	2,02	29,27
-13	8,6	312,27	3,12	45,29	212,27	2,12	30,79
-12	10,4	323,00	3,23	46,85	223,00	2,23	32,34
-11	12,2	334,00	3,34	48,44	234,00	2,34	33,94
-10	14	345,28	3,45	50,08	245,28	2,45	35,58
-9	15,8	356,85	3,57	51,76	256,85	2,57	37,25
-8	17,6	368,70	3,69	53,48	268,70	2,69	38,97
-7	19,4	380,85	3,81	55,24	280,85	2,81	40,73
-6	21,2	393,29	3,93	57,04	293,29	2,93	42,54
-5	23	406,04	4,06	58,89	306,04	3,06	44,39
-4	24,8	419,09	4,19	60,78	319,09	3,19	46,28
-3	26,6	432,45	4,32	62,72	332,45	3,32	48,22
-2	28,4	446,13	4,46	64,71	346,13	3,46	50,20
-1	30,2	460,13	4,60	66,74	360,13	3,60	52,23
0	32	474,46	4,74	68,82	374,46	3,74	54,31
1	33,8	489,11	4,89	70,94	389,11	3,89	56,44
2	35,6	504,10	5,04	73,11	404,10	4,04	58,61
3	37,4	519,43	5,19	75,34	419,43	4,19	60,83
4	39,2	535,10	5,35	77,61	435,10	4,35	63,11
5	41	551,12	5,51	79,93	451,12	4,51	65,43
6	42,8	567,49	5,67	82,31	467,49	4,67	67,80
7	44,6	584,22	5,84	84,74	484,22	4,84	70,23
8	46,4	601,31	6,01	87,21	501,31	5,01	72,71
9	48,2	618,77	6,19	89,75	518,77	5,19	75,24
10	50	636,60	6,37	92,33	536,60	5,37	77,83

HC Refrigerant R-290							
Temperature		Absolute pressure			Gauge pressure		
11	51,8	654,81	6,55	94,97	554,81	5,55	80,47
12	53,6	673,40	6,73	97,67	573,40	5,73	83,17
13	55,4	692,38	6,92	100,42	592,38	5,92	85,92
14	57,2	711,75	7,12	103,23	611,75	6,12	88,73
15	59	731,51	7,32	106,10	631,51	6,32	91,59
16	60,8	751,68	7,52	109,02	651,68	6,52	94,52
17	62,6	772,25	7,72	112,01	672,25	6,72	97,50
18	64,4	793,24	7,93	115,05	693,24	6,93	100,55
19	66,2	814,64	8,15	118,16	714,64	7,15	103,65
20	68	836,46	8,36	121,32	736,46	7,36	106,82
21	69,8	858,71	8,59	124,55	758,71	7,59	110,04
22	71,6	881,39	8,81	127,84	781,39	7,81	113,33
23	73,4	904,51	9,05	131,19	804,51	8,05	116,69
24	75,2	928,07	9,28	134,61	828,07	8,28	120,10
25	77	952,07	9,52	138,09	852,07	8,52	123,58
26	78,8	976,53	9,77	141,64	876,53	8,77	127,13
27	80,6	1001,45	10,01	145,25	901,45	9,01	130,75
28	82,4	1026,83	10,27	148,93	926,83	9,27	134,43
29	84,2	1052,68	10,53	152,68	952,68	9,53	138,18
30	86	1079,00	10,79	156,50	979,00	9,79	141,99
31	87,8	1105,79	11,06	160,38	1005,79	10,06	145,88
32	89,6	1133,08	11,33	164,34	1033,08	10,33	149,84
33	91,4	1160,85	11,61	168,37	1060,85	10,61	153,87
34	93,2	1189,12	11,89	172,47	1089,12	10,89	157,97
35	95	1217,88	12,18	176,64	1117,88	11,18	162,14
36	96,8	1247,16	12,47	180,89	1147,16	11,47	166,38
37	98,6	1276,94	12,77	185,21	1176,94	11,77	170,70
38	100,4	1307,24	13,07	189,60	1207,24	12,07	175,10
39	102,2	1338,07	13,38	194,07	1238,07	12,38	179,57
40	104	1369,42	13,69	198,62	1269,42	12,69	184,12
41	105,8	1401,31	14,01	203,25	1301,31	13,01	188,74
42	107,6	1433,73	14,34	207,95	1333,73	13,34	193,44
43	109,4	1466,71	14,67	212,73	1366,71	13,67	198,23
44	111,2	1500,23	15,00	217,59	1400,23	14,00	203,09
45	113	1534,31	15,34	222,54	1434,31	14,34	208,03
46	114,8	1568,96	15,69	227,56	1468,96	14,69	213,06
47	116,6	1604,18	16,04	232,67	1504,18	15,04	218,17
48	118,4	1639,97	16,40	237,86	1539,97	15,40	223,36
49	120,2	1676,34	16,76	243,14	1576,34	15,76	228,63
50	122	1713,30	17,13	248,50	1613,30	16,13	233,99
51	123,8	1750,86	17,51	253,94	1650,86	16,51	239,44
52	125,6	1789,02	17,89	259,48	1689,02	16,89	244,98
53	127,4	1827,79	18,28	265,10	1727,79	17,28	250,60
54	129,2	1867,17	18,67	270,81	1767,17	17,67	256,31
55	131	1907,17	19,07	276,62	1807,17	18,07	262,11
56	132,8	1947,80	19,48	282,51	1847,80	18,48	268,01
57	134,6	1989,07	19,89	288,49	1889,07	18,89	273,99
58	136,4	2030,98	20,31	294,57	1930,98	19,31	280,07
59	138,2	2073,54	20,74	300,75	1973,54	19,74	286,24
60	140	2116,75	21,17	307,01	2016,75	20,17	292,51

Part I : Technical Information

1. Summary

GDN16BE-K5EBA1A
GDN20BE-K5EBA1A



GDN20BE-K5EBA2A
GDN24BE-K5EBA2A

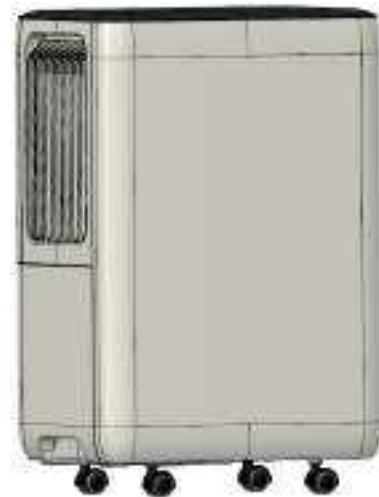

Gree Climat

Model List:

No	Model	Product code
1	GDN16BE-K5EBA1A	CK051037800
2	GDN20BE-K5EBA1A	CK051037701
3	GDN20BE-K5EBA2A	CK051043000
4	GDN24BE-K5EBA2A	CK051043100

2. Specifications

Model			GDN16BE-K5EBA1A
Product Code			CK051037800
Power Supply	Rated Voltage	V~	220-240
	Rated Frequency	Hz	50
	Phases		1
Rated Dehumidification Capacity	L/h		0.4
Power Input	W		315
Current Input	A		1.7
Set Humidity Range	%		30-80
Air Flow Volume(H/M/L)	m ³ /h		170/-/145
Fan Motor Speed	r/min		960/840
Fan Motor Power Output	W		5
Fan Motor RLA	A		0.118
Fan Motor Capacitor	μF		1
Fan Type			Centrifugal
Fan Diameter Length(DXL)	mm		Φ178.5X76.5
Throttling Method			Capillary
Fuse Current	A		3.15
Sound Pressure Level(H/M/L)	dB (A)		39/-/37
Sound Power Level(H/M/L)	dB (A)		53/-/-
Climate Type			T1
Isolation			↓
Moisture Protection			IPX0
Permissible Excessive Operating Pressure for the Discharge Side	MPa		3
Permissible Excessive Operating Pressure for the Suction Side	MPa		1.5
Dimension (WXHXD)	mm		352X482X240
Dimension of Carton Box(LXWXH)	mm		389X283X510
Dimension of Package(LXWXH)	mm		392X286X525
Application Area	m ²		22~28
Net Weight	kg		15.5
Gross Weight	kg		17
Refrigerant			R290
Refrigerant Charge	kg		0.065
Bucket Capacity	L		2.6/3.0
Control Type			Electronic
Evaporator	Evaporator Form		Aluminum Fin-copper Tube
	Evaporator Pipe Diameter	mm	Φ7
	Evaporator Row-fin Gap	mm	2-1.4
	Evaporator Coil Length (LXDXW)	mm	238X25.4X190.5
Condenser	Condenser Form		Aluminum Fin-copper Tube
	Condenser Pipe Diameter	mm	Φ5
	Condenser Rows-fin Gap	mm	2-1.4
	Condenser Coil Length (LXDXW)	mm	238X22.8X190.5
Compressor	Compressor Manufacturer		Sichuan Danfu Environment Technology Co.,Ltd
	Compressor Model		DFR60HF
	Compressor Type		Reciprocating
	Compressor Power Input	W	318
	Compressor Overload Protector		HPA-110
	Compressor LRA.	A	11.49
Compressor RLA	A	1.8	

The above data is subject to change without notice; please refer to the nameplate of the unit.

Model			GDN20BE-K5EBA1A
Product Code			CK051037701
Power Supply	Rated Voltage	V~	220-240
	Rated Frequency	Hz	50
	Phases		1
Rated Dehumidification Capacity		L/h	0.5
Power Input		W	350
Current Input		A	1.8
Set Humidity Range		%	30-80
Air Flow Volume(H/M/L)		m ³ /h	170-/145
Fan Motor Speed		r/min	960/840
Fan Motor Power Output		W	5
Fan Motor RLA		A	0.118
Fan Motor Capacitor		μF	1
Fan Type			Centrifugal
Fan Diameter Length(DXL)		mm	Φ178.5X76.5
Throttling Method			Capillary
Fuse Current		A	3.15
Sound Pressure Level(H/M/L)		dB (A)	39-/37
Sound Power Level(H/M/L)		dB (A)	53/-/-
Climate Type			T1
Isolation			I
Moisture Protection			IPX0
Permissible Excessive Operating Pressure for the Discharge Side		MPa	3
Permissible Excessive Operating Pressure for the Suction Side		MPa	1.5
Dimension (WXHXD)		mm	352X482X240
Dimension of Carton Box(LXWXH)		mm	389X283X510
Dimension of Package(LXWXH)		mm	392X286X525
Application Area		m ²	30~36
Net Weight		kg	15.5
Gross Weight		kg	17
Refrigerant			R290
Refrigerant Charge		kg	0.08
Bucket Capacity		L	2.6/3.0
Control Type			Electronic
Evaporator	Evaporator Form		Aluminum Fin-copper Tube
	Evaporator Pipe Diameter	mm	Φ7
	Evaporator Row-fin Gap	mm	2-1.4
	Evaporator Coil Length (LXDXW)	mm	238X25.4X190.5
Condenser	Condenser Form		Aluminum Fin-copper Tube
	Condenser Pipe Diameter	mm	Φ5
	Condenser Rows-fin Gap	mm	2-1.4
	Condenser Coil Length (LXDXW)	mm	238X22.8X190.5
Compressor	Compressor Manufacturer		Sichuan Danfu Environment Technology Co.,Ltd
	Compressor Model		DFR60HF
	Compressor Type		Reciprocating
	Compressor Power Input	W	318
	Compressor Overload Protector		HPA-110
	Compressor LRA.	A	11.49
	Compressor RLA	A	1.8

The above data is subject to change without notice; please refer to the nameplate of the unit.

Model			GDN20BE-K5EBA2A
Product Code			CK051043000
Power Supply	Rated Voltage	V~	220-240
	Rated Frequency	Hz	50
	Phases		1
Rated Dehumidification Capacity	L/h		0.5
Power Input	W		350
Current Input	A		1.8
Set Humidity Range	%		30-80
Air Flow Volume(H/M/L)	m ³ /h		170/-/145
Fan Motor Speed	r/min		960/840
Fan Motor Power Output	W		5
Fan Motor RLA	A		0.118
Fan Motor Capacitor	μF		1
Fan Type			Centrifugal
Fan Diameter Length(DXL)	mm		Φ178.5X76.5
Throttling Method			Capillary
Fuse Current	A		3.15
Sound Pressure Level(H/M/L)	dB (A)		39/-/37
Sound Power Level(H/M/L)	dB (A)		53/-/-
Climate Type			T1
Isolation			I
Moisture Protection			IPX0
Permissible Excessive Operating Pressure for the Discharge Side	MPa		3
Permissible Excessive Operating Pressure for the Suction Side	MPa		1.5
Dimension (WXHXD)	mm		352X490X240
Dimension of Carton Box(LXWXH)	mm		389X283X522
Dimension of Package(LXWXH)	mm		392X286X537
Application Area	m ²		30~36
Net Weight	kg		16
Gross Weight	kg		17
Refrigerant			R290
Refrigerant Charge	kg		0.08
Bucket Capacity	L		2.6/3.0
Control Type			Electronic
Evaporator	Evaporator Form		Aluminum Fin-copper Tube
	Evaporator Pipe Diameter	mm	Φ7
	Evaporator Row-fin Gap	mm	2-1.4
	Evaporator Coil Length (LXD _{XW})	mm	238X25.4X190.5
Condenser	Condenser Form		Aluminum Fin-copper Tube
	Condenser Pipe Diameter	mm	Φ5
	Condenser Rows-fin Gap	mm	2-1.4
	Condenser Coil Length (LXD _{XW})	mm	238X22.8X190.5
Compressor	Compressor Manufacturer		Sichuan Danfu Environment Technology Co.,Ltd
	Compressor Model		DFR60HF
	Compressor Type		Reciprocating
	Compressor Power Input	W	318
	Compressor Overload Protector		HPA-110
	Compressor LRA.	A	11.49
Compressor RLA	A	1.8	

The above data is subject to change without notice; please refer to the nameplate of the unit.

Model			GDN24BE-K5EBA2A
Product Code			CK051043100
Power Supply	Rated Voltage	V~	220-240
	Rated Frequency	Hz	50
	Phases		1
Rated Dehumidification Capacity		L/h	0.51
Power Input		W	355
Current Input		A	1.9
Set Humidity Range		%	30-80
Air Flow Volume(H/M/L)		m ³ /h	220/-/155
Fan Motor Speed		r/min	1130/930
Fan Motor Power Output		W	12
Fan Motor RLA		A	0.168
Fan Motor Capacitor		μF	1.5
Fan Type			Centrifugal
Fan Diameter Length(DXL)		mm	Φ178.5X76.5
Throttling Method			Capillary
Fuse Current		A	3.15
Sound Pressure Level(H/M/L)		dB (A)	44/-/42
Sound Power Level(H/M/L)		dB (A)	56/-/-
Climate Type			T1
Isolation			I
Moisture Protection			IPX0
Permissible Excessive Operating Pressure for the Discharge Side		MPa	3
Permissible Excessive Operating Pressure for the Suction Side		MPa	1.5
Dimension (WXHXD)		mm	352X490X240
Dimension of Carton Box(LXWXH)		mm	389X283X522
Dimension of Package(LXWXH)		mm	392X286X537
Application Area		m ²	36~42
Net Weight		kg	16
Gross Weight		kg	17
Refrigerant			R290
Refrigerant Charge		kg	0.075
Bucket Capacity		L	2.6/3.0
Control Type			Electronic
Evaporator	Evaporator Form		Aluminum Fin-copper Tube
	Evaporator Pipe Diameter	mm	Φ7
	Evaporator Row-fin Gap	mm	2-1.4
	Evaporator Coil Length (LXDXW)	mm	238X25.4X190.5
Condenser	Condenser Form		Aluminum Fin-copper Tube
	Condenser Pipe Diameter	mm	Φ5
	Condenser Rows-fin Gap	mm	2-1.4
	Condenser Coil Length (LXDXW)	mm	238X22.8X190.5
Compressor	Compressor Manufacturer		Sichuan Danfu Environment Technology Co.,Ltd
	Compressor Model		DFR60HF
	Compressor Type		Reciprocating
	Compressor Power Input	W	338
	Compressor Overload Protector		HPA-110
	Compressor LRA.	A	11.49
	Compressor RLA	A	1.8

The above data is subject to change without notice; please refer to the nameplate of the unit.

3.Outline Dimension Diagram

GDN16BE-K5EBA1A GDN20BE-K5EBA1A

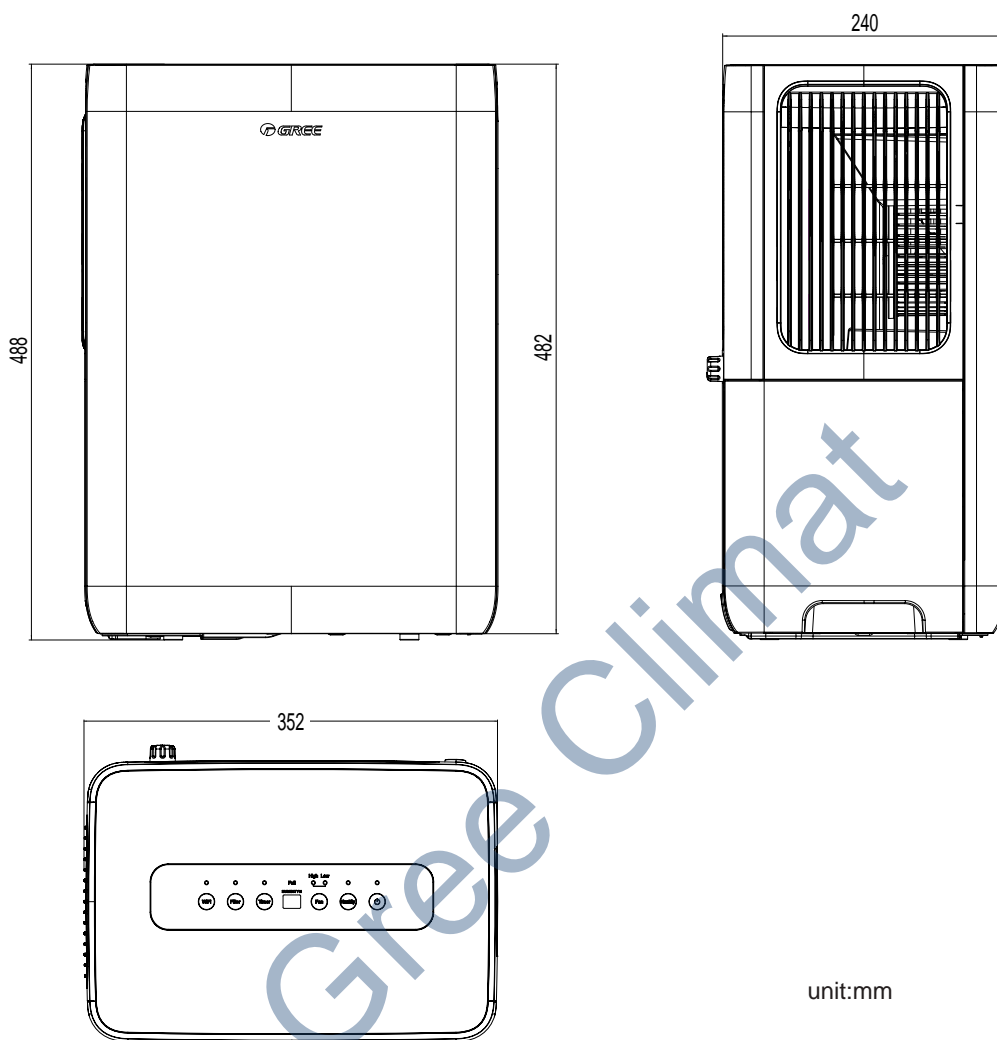

GDN20BE-K5EBA2A GDN24BE-K5EBA2A

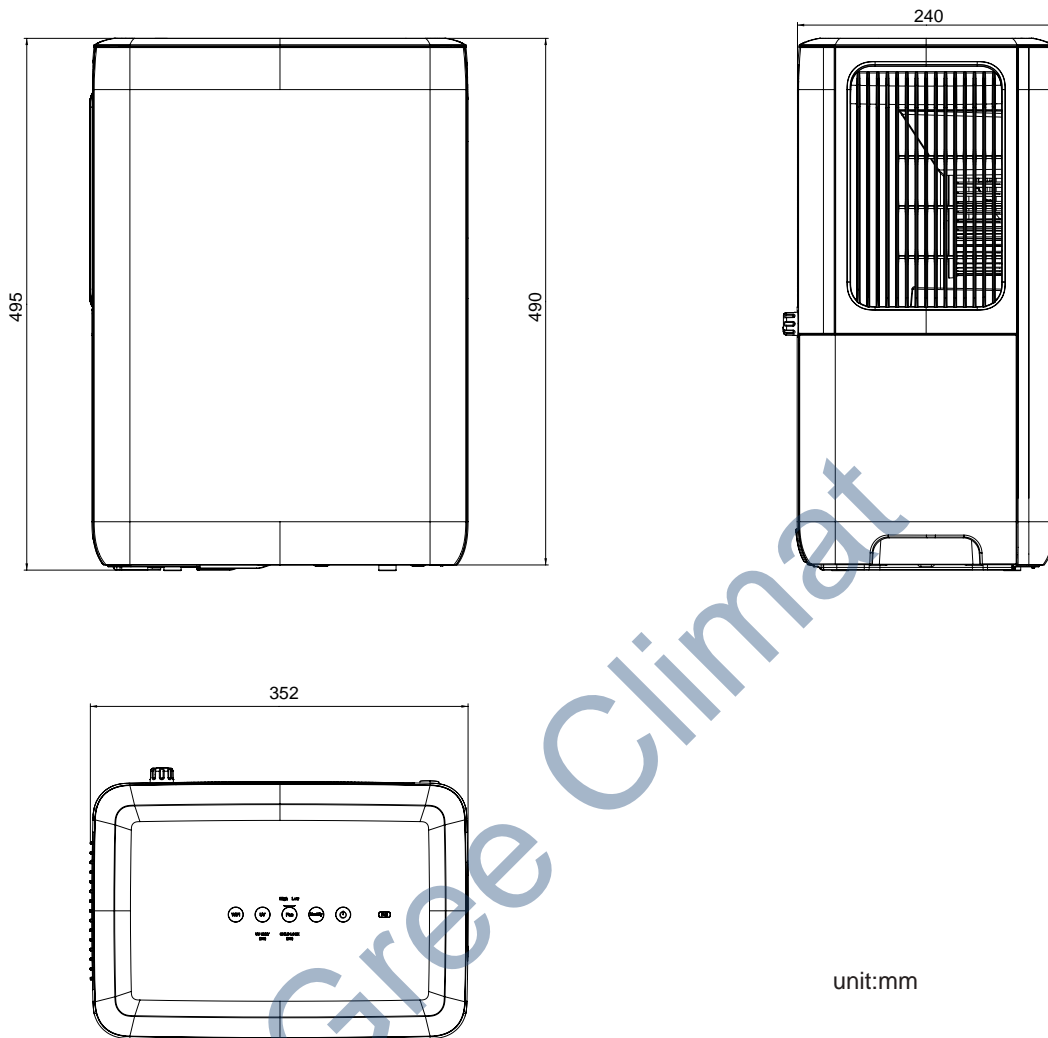

4.Refrigerant System Diagram

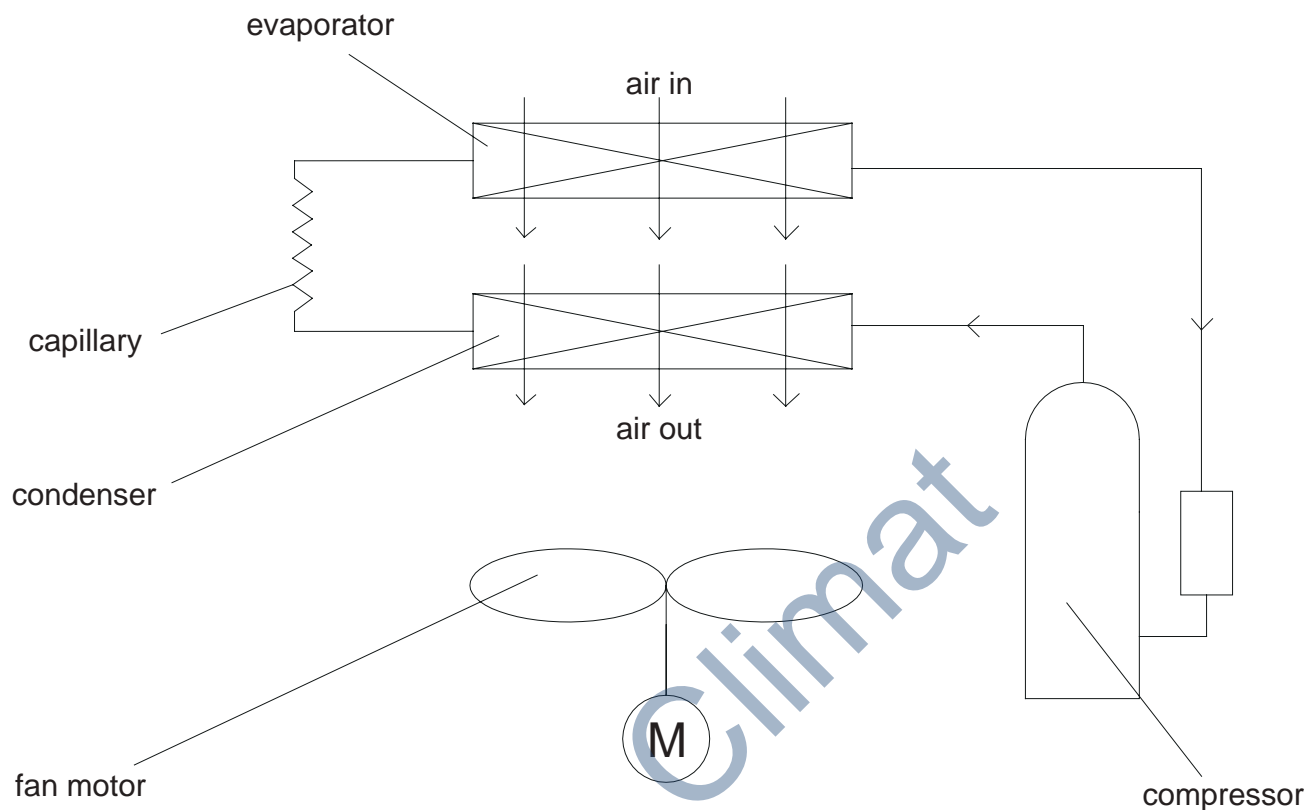

Dehumidifying principle of dehumidifier:

When temperature is decreased to the temperature point of dew, water vapor in humid air will condensate. Dehumidifier is dehumidifying the air by using this principle.

During operation of the system, air will pass through evaporator and condenser in turn and then be discharged due to centrifugal blade. When the air is passing through evaporator, refrigerant will absorb the heat in air to let its temperature decrease to the temperature point of dew, water vapor in air will condensate. Condensate water comes into water tank through water tray, or is discharged directly through drainage hose. The saturated low-temperature air passed through the evaporator will absorb the heat when flowing along the condenser, and then become the dry air. Under normal condition, the nearby air will become warm during operation of dehumidifier.

5. Electrical Part

5.1 Wiring Diagram

• Instruction

Symbol	Symbol Color	Symbol	Symbol Color	Symbol	Name
WH	White	GN	Green	COMP	Compressor
YE	Yellow	BN	Brown	⊕	Grounding wire
RD	Red	BU	Blue	/	/
YEGN	Yellow/Green	BK	Black	/	/
VT	Violet	OG	Orange	/	/

GDN16BE-K5EBA1A GDN20BE-K5EBA1A

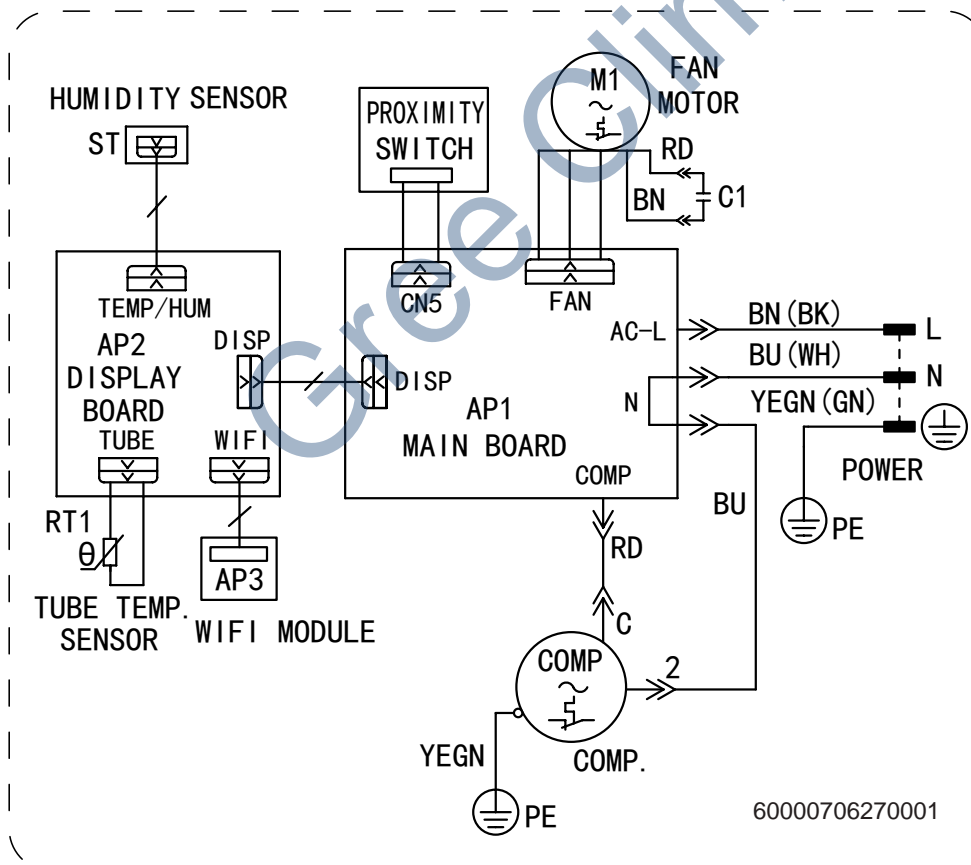

GDN20BE-K5EBA2A GDN24BE-K5EBA2A

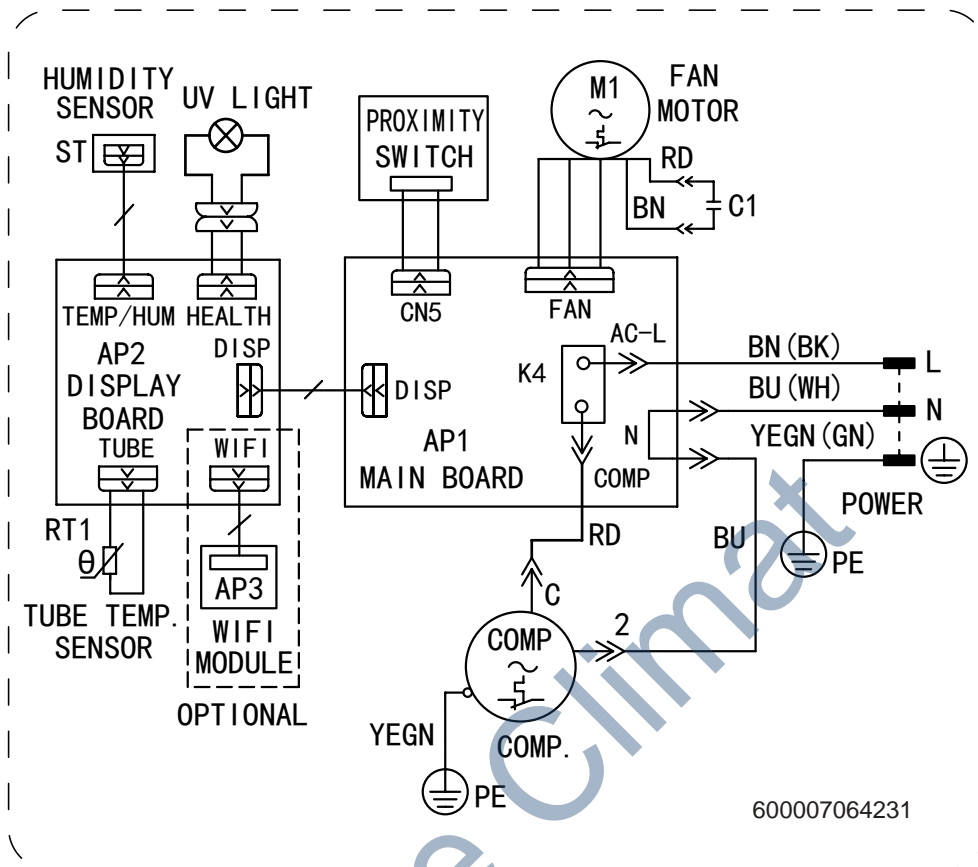

These circuit diagrams are subject to change without notice ,please refer to the one supplied with the unit.

GDN20BE-K5EBA2A GDN24BE-K5EBA2A

• Top view

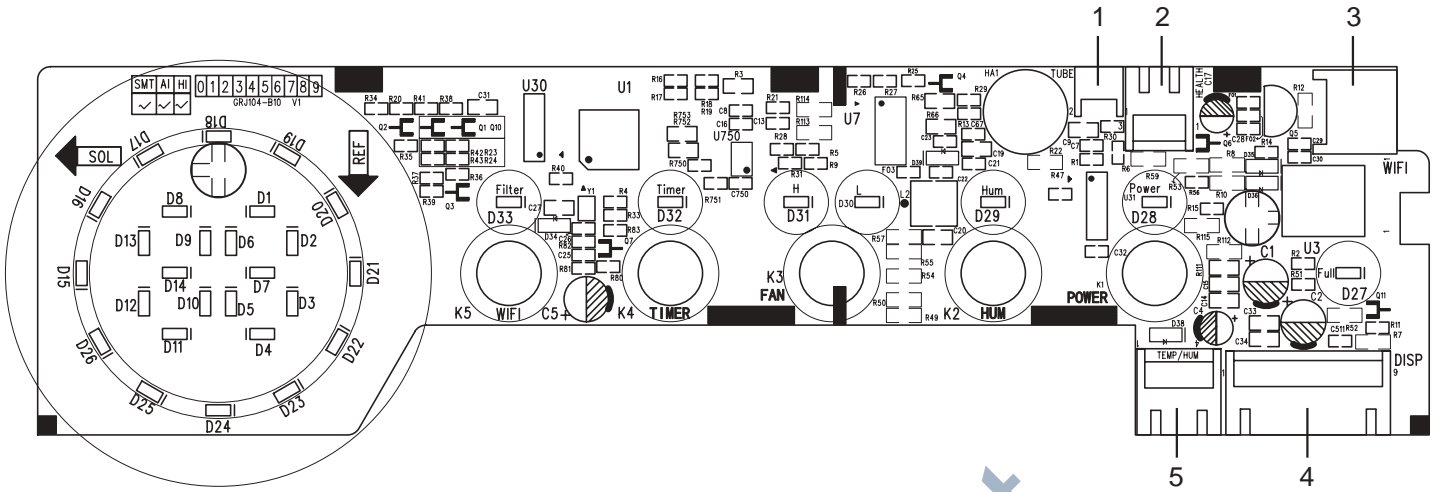

No.	Name
1	Interface of tube temperature sensor
2	Health function
3	WiFi needle stand
4	Interface of main board
5	Circuit interface of temperature/humidity inspection

• Bottom view

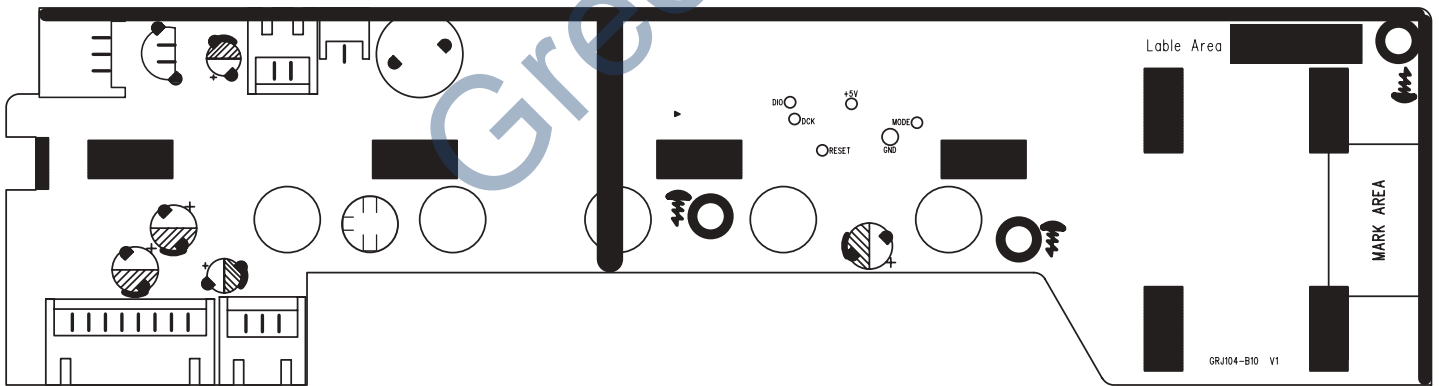

6. Function and Control

6.1 Control Panel Instruction

GDN16BE-K5EBA1A GDN20BE-K5EBA1A

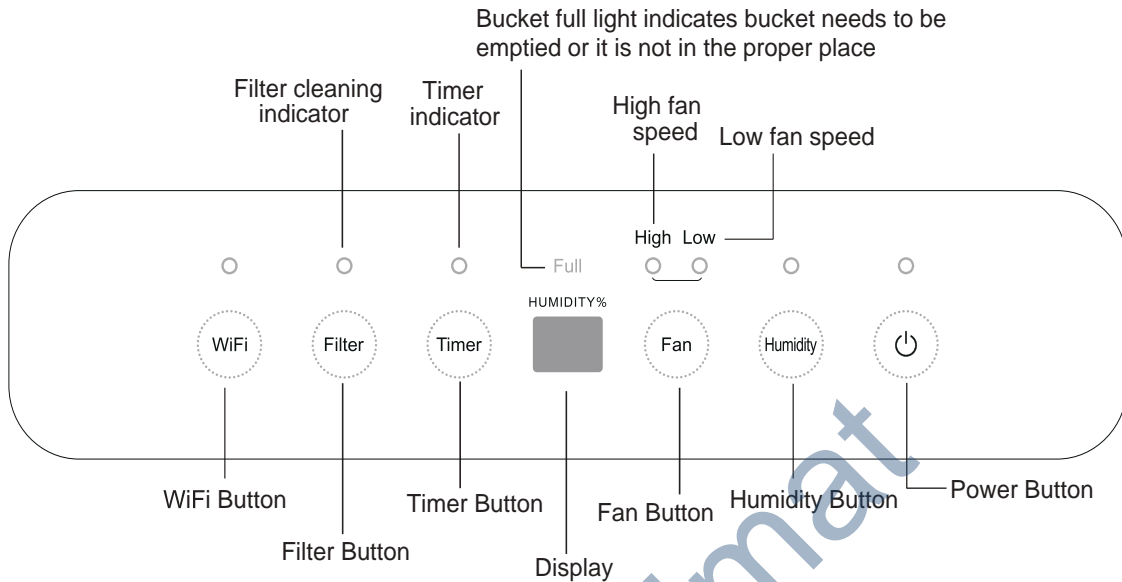

Notes:

- Water bucket must be correctly installed for the dehumidifier to operate.
- Do not remove the bucket while unit is in operation.
- If you want to use drain hose to drain water away, please install the hose according to section "Drainage method".
- Each time pressing the effective button on the control panel will give out a "beep" sound.

Basic Functions of the Buttons

1 Power Button

Press this button to turn on/off dehumidifier.

2 Humidity Button

As for setting the humidity, after each pressing of humidity button, the set humidity will increase 5% in the range of 30%-80% circularly; Hold the humidity button can adjust the humidity quickly.

3 Fan Button

Press this button can freely switch from high fan speed to low fan speed. When you need fast dehumidification, select high fan speed; when you need the unit to work quietly, select low fan speed.

4 Timer Button

Press this button can make the unit work on designated time. The timer function takes hour as unit, and 0-24h can be circularly set. Duration of timer can be temporarily displayed on the panel.

5 Filter Button

Press this button to turn off Filter Cleaning Indicator. (When dehumidifier has been operating for 250 hours, Filter Cleaning Indicator will be lit up to remind user of filter cleaning.

6 WiFi Button 

Whether the unit is turned on or turned off, press WiFi button can turn on or turn off WiFi function;
Whether the unit or WiFi is turned on or turned off, hold WiFi button for 5s can reset WiFi. At the same time, WiFi function will be turned on.

7 Display 

The humidity display window is defaulted to display current environment humidity. If press humidity button to adjust the humidity, it will display the set humidity. 5s later, it will turn back to display the ambient humidity.

Other Instructions

1. Alarm Warning

If bucket is full or not locked into place for over 3min, buzzer will beep for 10s to remind you to empty bucket or put it back into the correct place.

2. Auto Stop

When bucket is full, removed or not placed correctly or the humidity is 5%lower than the set humidity, unit will automatically stop.

3. Memory Function

If power is lost, all of the control settings are remembered. So when power is restored, the unit will start back up in the settings it was in when power was lost.

4. Bucket full light

This indicates that bucket is full or removed or not placed correctly.

5. Clean the Filter On indicator light

When dehumidifier has been operating for 250 hours, Filter Cleaning Indicator will be lit up to remind user of filter cleaning.

Gree Climat

GDN20BE-K5EBA2A GDN24BE-K5EBA2A

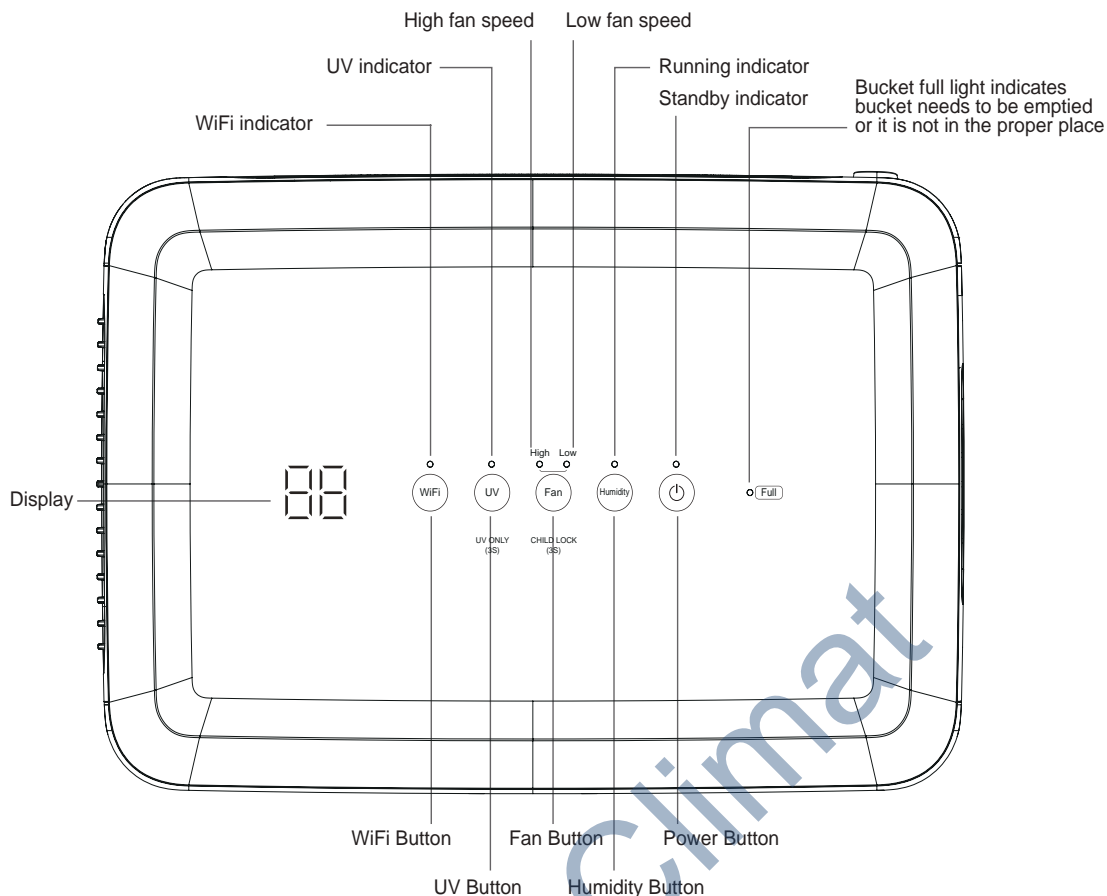

Notes:

- Water bucket must be correctly installed for the dehumidifier to operate.
- Do not remove the bucket while unit is in operation.
- If you want to use drain hose to drain water away, please install the hose according to section "Drainage method".
- Each time pressing the effective button on the control panel will give out a "beep" sound.

Basic Functions of the Buttons

1 Power Button

Press this button to turn on/off dehumidifier.

2 Humidity Button

As for setting the humidity, after each pressing of humidity button, the set humidity will increase 5% in the range of 30%-80% circularly; Hold the humidity button can adjust the humidity quickly.

3 Fan Button

Press this button can freely switch from high fan speed to low fan speed. When you need fast dehumidification, select high fan speed; when you need the unit to work quietly, select low fan speed. Hold this button for 3S to enter or exit child lock status. When the unit enters child lock status, the display window will flash "LC" 3 times; at this time, pressing other buttons will be invalid and "LC" will be displayed.

4 UV Button



Under dehumidification mode, it's defaulted that UV function is turned on. Press this button once only to turn off or turn on the UV function. Hold this button for 3S to enter or exit single UV mode. Under single UV mode, the dehumidification function will be off, and the display window will display "- -".

5 WiFi Button 

Whether the unit is turned on or turned off, press WiFi button can turn on or turn off WiFi function;
Whether the unit or WiFi is turned on or turned off, hold WiFi button for 5s can reset WiFi. At the same time, WiFi function will be turned on.

6 Display 

The humidity display window is defaulted to display current environment humidity. If press humidity button to adjust the humidity, it will display the set humidity. 5s later, it will turn back to display the ambient humidity.

7 Combination button  + 

Under on status, hold combination button (uv button + fan button) for 3s can turn on or turn off the nixie tube.

Other Instructions

1. Alarm Warning

If bucket is full or not locked into place for over 3min, buzzer will beep for 10s to remind you to empty bucket or put it back into the correct place.

2. Auto Stop

When bucket is full, removed or not placed correctly or the humidity is 5%lower than the set humidity, unit will automatically stop.

3. Memory Function

If power is lost, all of the control settings are remembered. So when power is restored, the unit will start back up in the settings it was in when power was lost.

4. Bucket full light

This indicates that bucket is full or removed or not placed correctly.

Gree Climat

6.2 Introduction of Basic Mode Function

1. System Basic Function

Adjustment of humidity takes 5% as a unit, user can select circularly within 30%~80%. The set humidity is always displayed on the control panel

- a. When $HUMIDITY_{preset} \leq HUMIDITY_{amb} - 5\%$, compressor and fan will run.
- b. When $HUMIDITY_{preset} \geq HUMIDITY_{amb} + 5\%$, compressor stop to run and fan will stop operation after 3min.
- c. When $HUMIDITY_{amb} - 5\% < HUMIDITY_{preset} < HUMIDITY_{amb} + 5\%$, when compressor is operation, it will run with condition a; when compressor stops, it will run with condition b; If under this condition when the unit is on, the compressor is off and fan will stop to run after 3min delay.

2. Protection Function

(1) Working temperature range

- a. Detect the unit after energized, when $2^{\circ}\text{C} \leq T_{amb} < 37^{\circ}\text{C}$, the unit is running normally; when $T_{amb} < 2^{\circ}\text{C}$ or $T_{amb} \geq 37^{\circ}\text{C}$, the compressor stops, and fan will run with the detected temperature humidity;
- b. During operation, when $T_{amb} < 2^{\circ}\text{C}$ or $T_{amb} \geq 37^{\circ}\text{C}$, the compressor stops, and fan will run with the detected temperature humidity; when $2^{\circ}\text{C} \leq T_{amb} < 37^{\circ}\text{C}$, the compressor will be started up.

(2) Compressor protection

- a. After energization, under any situation and after compressor stops, it will restart 3min delay at least.
- b. Under operation state except temperature sensor malfunction, on/off button, water-blow protection, after compressor starts up, it will stop after it runs for 3mins at least.

(3) Detection for temperature sensor malfunction

When there's malfunction for temperature sensor, compressor and fan stop operation. LED indicator is OFF and buttons are invalid.

Nixie tube displays F2. After the temperature is resumed normally, restart the unit.

(4) Water blow protection (off switch)

- a. The water blow protection will be occurred when the water level of water tank is exceeded. After water blow protection, compressor stops and fan stops after 3mins. If water blow protection occurred for 3min, the buzzer will stop after it gives out a beep for 10s, indicator of water blow will blinks and all the buttons are invalid except power button. When the water level or assembly of water tank resume to normal, signal of water blow protection will cancelled, indicator is off, buzzer stops to give out a beep and resume to normal operation state.
- b. When the unit is off, water blow protection is occurred, water blow indicator blinks, compressor and fan stops, all the buttons are invalid except on/off buttons. When the unit is on, water blow indicator blinks, buzzer will not give out a beep, compressor and fan stops.

3. Other Functions

Power-off memory: Upon power failure, the unit after power recovery will automatically start to run according to memory content.

6.3 GREE+ App Operation Manual

Control Flow Chart

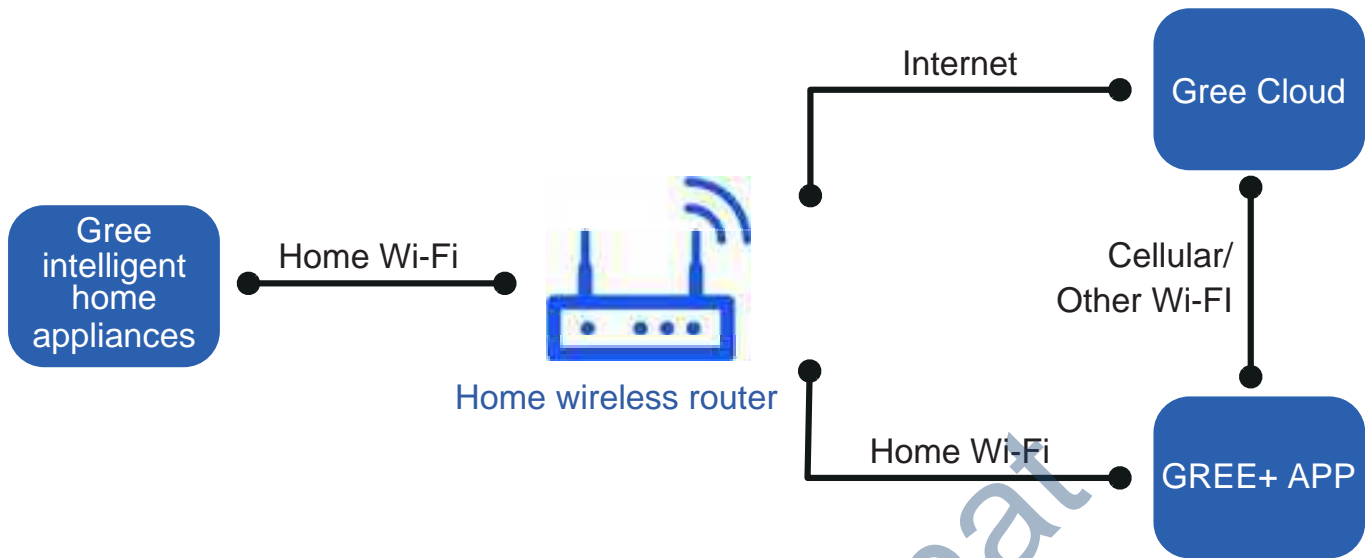

Operating Systems

Requirement for User's smart phone:



iOS system
Support iOS7.0 and above version



Android system
Support Android 4.4 and above version

Download and installation



GREE+ App Download Linkage

Scan the QR code or search "GREE+" in the application market to download and install it. When "GREE+" App is installed, register the account and add the device to achieve long-distance control and LAN control of Gree smart home appliances. For more information, please refer to "Help" in App.

6.4 Ewpe Smart App Operation Manual

Control Flow Chart

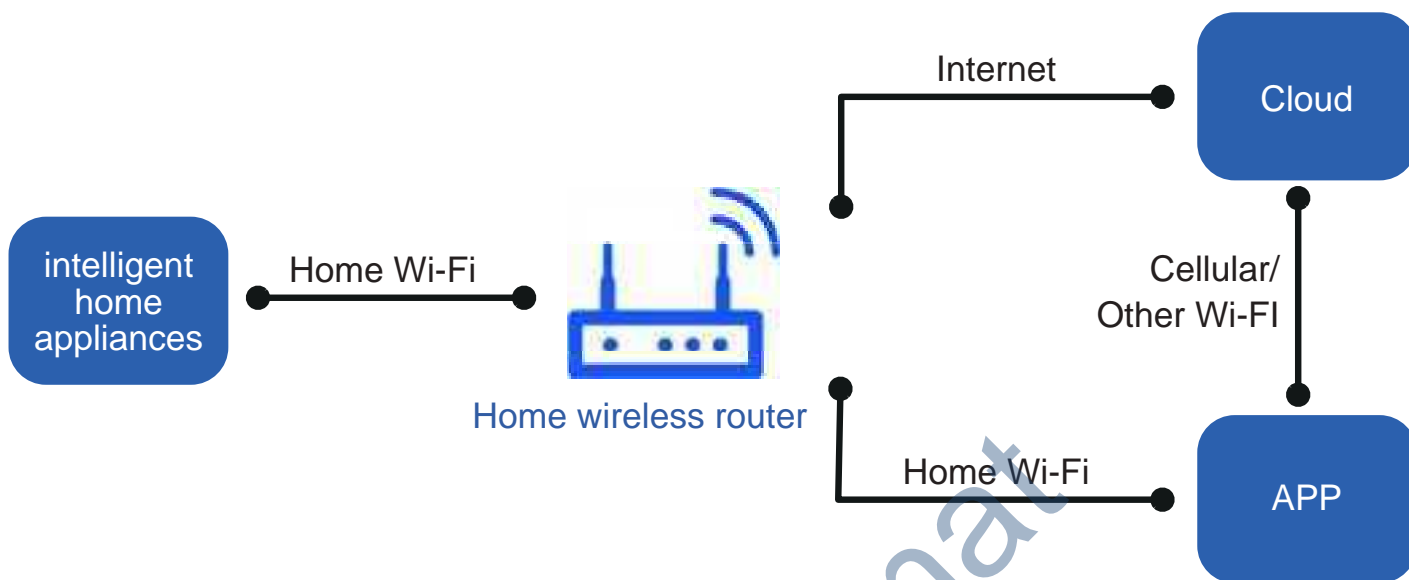

Operating Systems

Requirement for User's smart phone:



iOS system
Support iOS7.0 and above version



Android system
Support Android 4.4 and above version

Download and installation



App Download Linkage

Scan the QR code or search "Ewpe Smart" in the application market to download and install it. When "Ewpe Smart" App is installed, register the account and add the device to achieve long-distance control and LAN control of smart home appliances. For more information, please refer to "Help" in App.

Part II : Maintenance

7. Notes Maintenance

Safety Precautions: Important!

Please read the safety precautions carefully before maintenance:

The following contents are very important for installation and maintenance.

Please follow the instructions below.

- The maintenance must accord with the instructions.
- Comply with all national electrical codes and local electrical codes.
- Pay attention to the warnings and cautions in this manual.
- Be caution during maintenance. Prohibit incorrect operation to prevent electric shock and other accidents.



Warnings

Electrical Safety Precautions:

1. Cut off the power supply before maintenance.
2. Specialized circuit must be applied; prohibit sharing the same circuit with other electric appliances; protection switch must be installed.
3. Have the unit adequately grounded. The grounding wire can't be used for other purposes.
4. The live wire, neutral wire and grounding wire of power supply must be corresponding to the live wire, neutral wire and grounding wire of the dehumidifier.
5. The power cord can't be pressed by hard objects.
6. If the power cord or connection wire is not long enough, please get the specialized power cord or connection wire from the manufacture or distributor. Prohibit prolong the wire by yourself.
7. Replace the fuse with a new one of the same specification if it is burnt down; don't replace it with a copper wire or conducting wire.
8. Use the power supply with same voltage and frequency as shown in rating label.
9. Do not pull out the power plug when the unit is operating to avoid damaging the circuit.
10. Do not place anything at the top of dehumidifier; ensure the air outlet or air inlet is not blocked; do not use the unit near wall and curtain.
11. Do not use heating equipment around the unit.

Refrigerant Safety Precautions:

When refrigerant leaks or requires discharge during installation, maintenance, or disassembly, it should be handled by certified professionals or otherwise in compliance with local laws and regulations.

1. This unit adopts R290 refrigerant. System maintenance is strictly prohibited.
2. If the refrigerant leaks or the pipeline is damaged, it is forbidden to conduct the maintenance. The unit should be recycled and disposed according to local regulations.
3. It is strictly forbidden to cut or weld the refrigerant. Otherwise, it may lead to explosion.

Improper installation may lead to fire hazard explosion, electric shock or injury.



Appliance filled with flammable gas R290.



Before install and use the appliance, read the owner's manual first.



Before install the appliance, read the installation manual first.



Before repair the appliance, read the service manual first.

The Refrigerant

- To realize the function of the air conditioner unit, a special refrigerant circulates in the system. The used refrigerant is the fluoride R290, which is specially cleaned. The refrigerant is flammable and inodorous. Furthermore, it can lead to explosion under certain conditions.
- Compared to common refrigerants, R290 is a nonpolluting refrigerant with no harm to the ozoneosphere. The influence upon the greenhouse effect is also lower. R290 has got very good thermodynamic features which lead to a really high energy efficiency. The units therefore need a less filling.
- Please refer to the nameplate for the charging quantity of R290.

WARNING :

- Appliance filled with flammable gas R290.
- Appliance shall be installed, operated and stored in a room with a floor area larger than 4m².
- The appliance shall be stored in a room without continuously operating ignition sources. (for example: open flames, an operating gas appliance or an operating electric heater.)
- The appliance shall be stored in a well-ventilated area where the room size corresponds to the room area as specified for operation.
- The appliance shall be stored so as to prevent mechanical damage from occurring.
- Ducts connected to an appliance shall not contain an ignition source.
- Keep any required ventilation openings clear of obstruction.
- Do not pierce or burn.
- Be aware that refrigerants may not contain an odour.
- Do not use means to accelerate the defrosting process or to clean, other than those recommended by the manufacturer.
- Servicing shall be performed only as recommended by the manufacturer.
- Should repair be necessary, contact your nearest authorized Service Centre. Any repairs carried out by unqualified personnel may be dangerous.
- Compliance with national gas regulations shall be observed.
- Read specialist's manual.

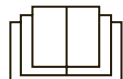

2. Air filter

The filter should be checked and cleaned at least every 250 hours of operation or more often if necessary.

To remove: Press the "PUSH" above the filter with two hands simultaneously, then the filter can be removed.

To clean: Clean the filter in warm, soapy water. Rinse it and let the filter dry before replacing it.

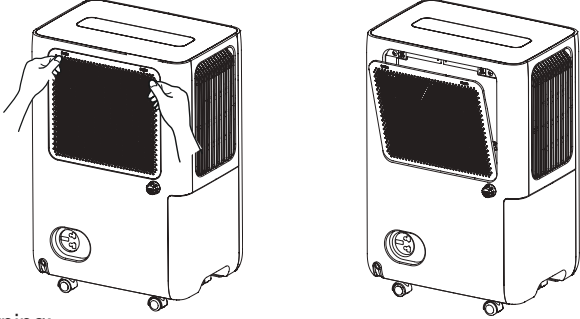

Warning:

- Do not operate the dehumidifier without a filter. Otherwise the evaporator will catch dust and affect units performance.
- Do not dry the air filter with fire or electric hair dryer. Otherwise the air filter may be unshaped or caught on fire.
- Don't use dust catcher or brush to clean the air filter. Otherwise the air filter may be destroyed.

8.3 Check Before Use-season

- Check whether air outlet is blocked.
- Check whether power plug and power socket are in good condition.
- Check whether air filter is clean.
- Check whether drain hose is damaged.

8.4 Care After Use-season

- Disconnect power.
- Clean air filter and case.
- Clean dust and obstacle of the dehumidifier.
- Empty the water bucket.

8.5 Long-time Storage

If you wnot use the dehumidifier for a long time ,we suggest that you follow the steps below in order to maintain the unit in good condition.

- Make sure the bucket is clear of water and drain hose is removed.
- Clean the unit and wrap it well to prevent the gathering of dust.

9. Maintenance

9.1 Safety Principle of Maintenance

1. The maintenance spot must have good ventilation. Do not close the door or the window.
2. Do not use naked flame, including welding, smoking. Do not use power tools. Do not use mobile phone. Tell the user not to cook with naked flame.
3. Take antistatic measures, including wearing pure cotton clothes and gloves etc.
4. If flammable refrigerant leakage is found during maintenance, it is a must to reinforce ventilation and take effective protective measures.
5. During maintenance, it is necessary to keep the spot safe when fetching the lacked spare parts.
6. It is necessary to keep the case of the air conditioner grounded during maintenance.
7. The maintenance unrelated to refrigerant vessel, inner refrigerant pipe and cooling component can be performed in the user's place, including cleaning the cooling system and sludging.
8. Ensure that the density tester is working during maintenance.
9. Ensure there is necessary safety precaution and emergency measures on the spot. Put suitable fire extinguishers (CO₂ or dry powder) in the nearest area.
10. There must be natural ventilation in the maintenance spot.
11. The maintenance staff shall take safety actions.
12. Paste suitable signs such as "No Smoking" and "No Entry".

9.2 Preparation before Maintenance

1. Inspection of Environment
 - (1) Ensure that electric product with radiation is power off in the maintenance area. All the persons in the room shall turn off the mobile phone.
 - (2) Check if there is refrigerant leakage in the maintenance area. Ensure that all the leak testers are suitable for this air conditioner.
 - (3) Ensure that the room area reaches the requirement.
 - (4) Check if the maintenance area is ventilated. Keep the room ventilated.
2. Inspection of Air Conditioner
 - (1) Ensure that the air conditioner is reliably grounded.
 - (2) Ensure that the power supply of the air conditioner is cut off. Discharge the electricity of the capacitor. If power supply is necessary, perform leak test to prevent the potential danger.
3. Inspection of Maintenance Equipment
 - (1) Check if the maintenance equipment is suitable for the refrigerant. Only the special equipment recommended by the air conditioner supplier can be used.
 - (2) The set alarm density of the leak tester shall not be higher than 25% of the LEL. The tester must keep operating during maintenance.
4. Leak Test before Maintenance
 - (1) After cutting off the power supply, perform leak test with the recommended leak detector or density tester (pump suction type) (ensure the equipment is calibrated; leakage ratio of leak detector is 2g/year.)

Note: do not use solvent with chlorine in case causing corrosion of the steel pipe.

 - (2) If leakage is found, remove all fire source ensure good ventilation of the area.
5. Check List

No.	Check information	Result	Yes/No
1	Maintenance equipment is complete		
2	Persons in the maintenance area turn off the mobile phone.		
3	Power supply of tools is 2m away.		
4	Density tester can be used.		
5	Other tools are normal.		
6	Maintenance staffs are qualified.		
7	The spare parts are provided by the manufacturer and qualified.		
8	The air conditioner needed to be serviced is under safe state.		
9	The wire of power socket is reliably connected.		
10	There is natural ventilation in maintenance area.		
11	There is no operating electric appliance or naked flame within 2m of Maintenance area.		

9.3 Maintenance Cautions

If it is necessary to replace components, all the components used shall be made by manufacturer. Otherwise, the supplier shall not bear the responsibility.

1.Maintenance of Electrical Parts

- (1) Replace the power cord and connecting wire with that of the same specification.
- (2) When inspecting the circuit with power on, check if there is electric leakage for the metal component such as evaporator or condenser. During inspection, do not touch the circuit so as to prevent electric shock.
- (3) When inspecting the capacitor, ensure that the maintenance area is well ventilated. After conforming there is no refrigeration leakage, discharge electricity of capacitor.
- (4) Before replacing the component, cut of the power supply of the air conditioner.
- (5) Cut off the power before disconnecting and connecting the wire. Disconnect the live wire first and then ground wire.
- (6) During maintenance, do not remove the protective component. Use the component of same supplier and specification.
- (7) When servicing the hermetic parts, cut of the power of the air conditioner before opening the sealing cover. If it is necessary to use power supply, perform leak test to prevent potential danger.
- (8) Do not replace the case which may affect the protective grade.
- (9) Ensure that the sealing material is not degraded and that it can prevent entry of flammable gas. The parts used for replacement must reach the requirement of the supplier.

(1).Replace electric box

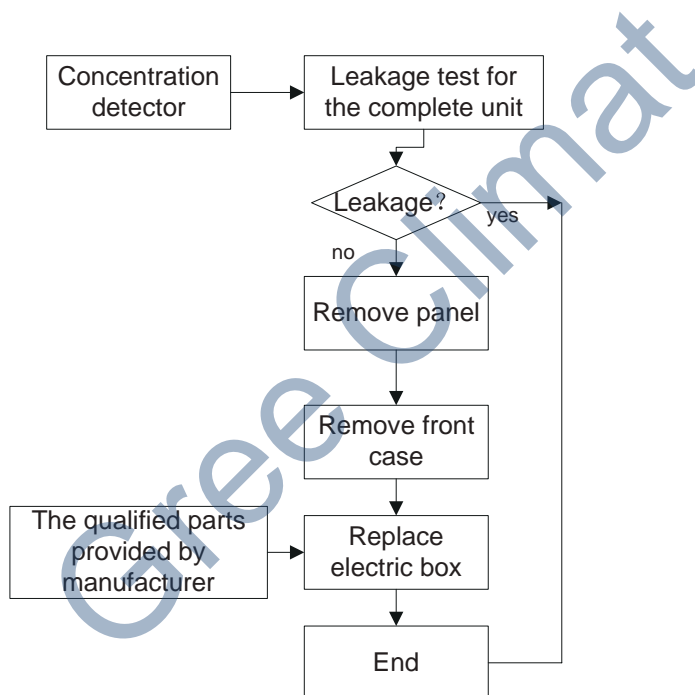

2.Maintenance of Refrigeration System

Before the maintenance, check whether there is any leakage or blockage in the refrigeration system. If yes, it is forbidden to conduct the maintenance. The unit should be recycled and disposed according to local regulations.

(2).Replace main board

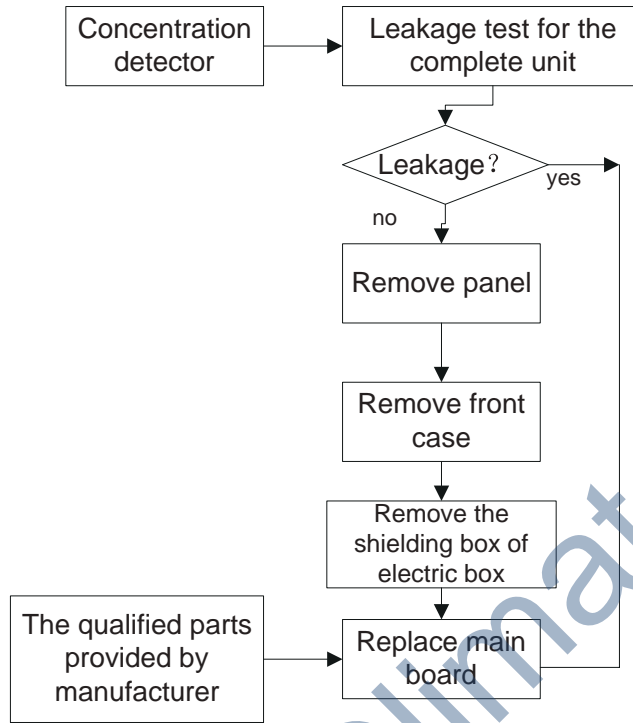

Gree Climat

9.5 Malfunction Detection Flowchart

1. Malfunction of temperature sensor F1, F2

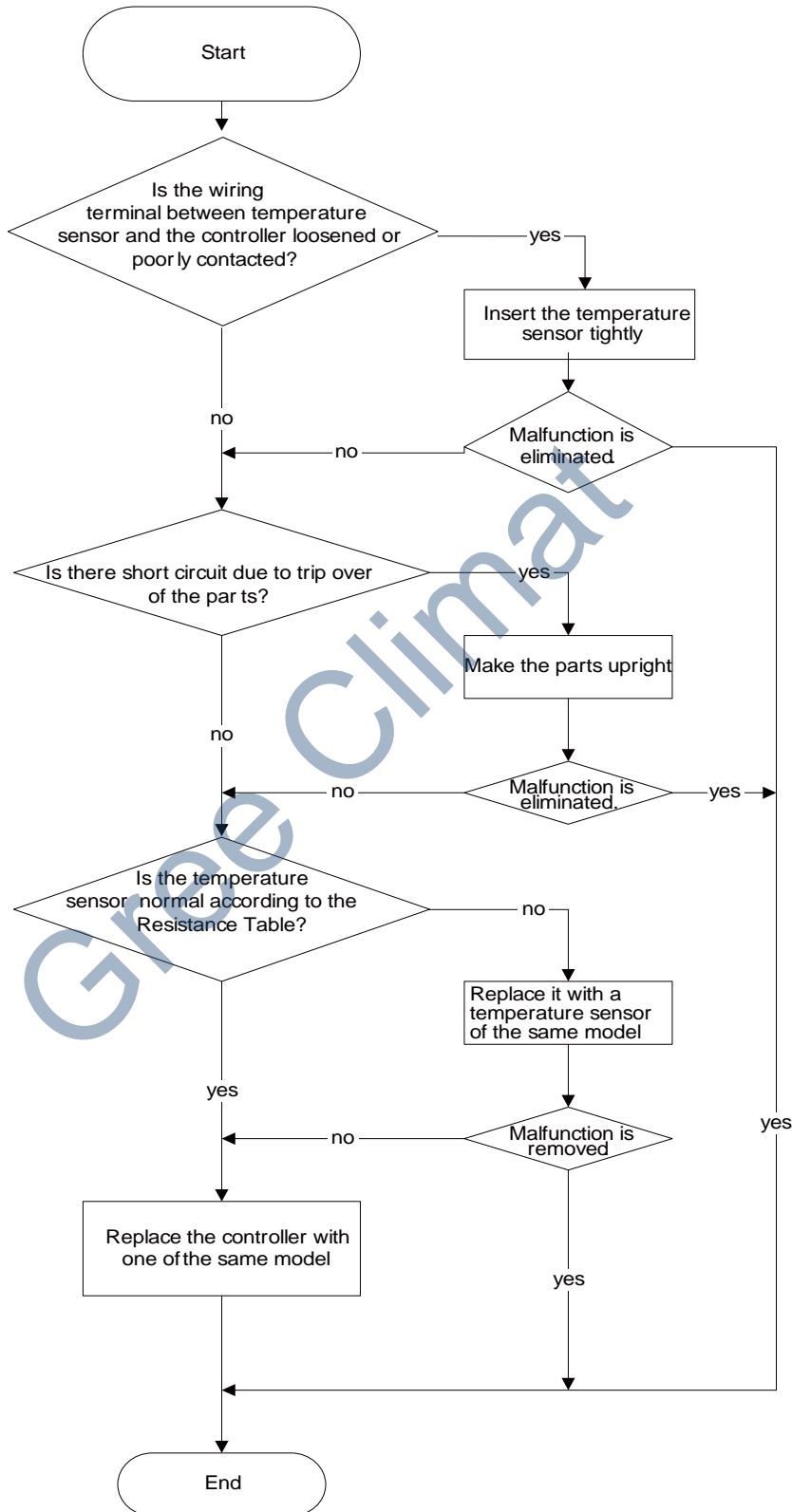

3. Malfunction of Insufficient Refrigerant protection F0

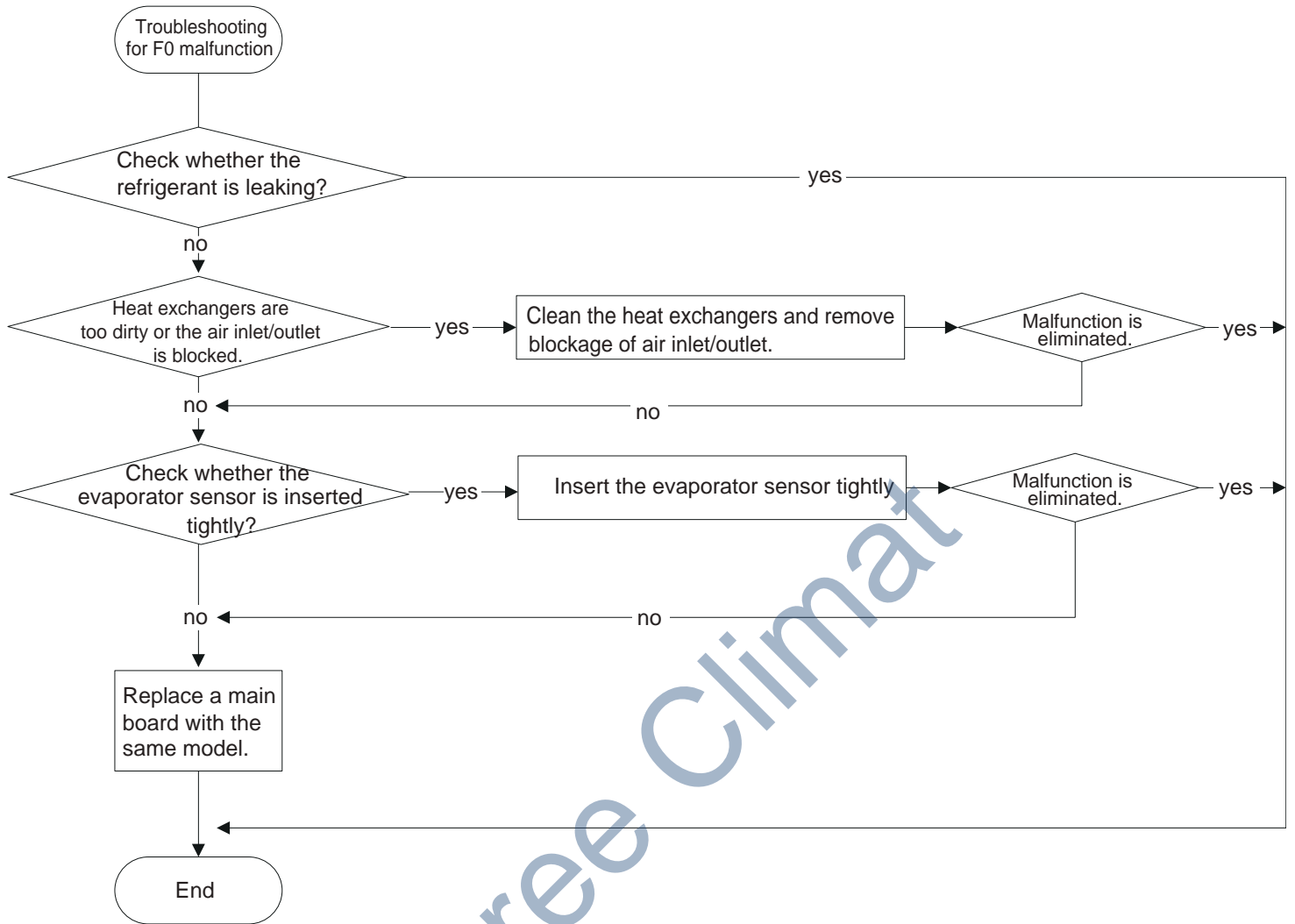

Gree Climat

4. High-temperature overload protection H3

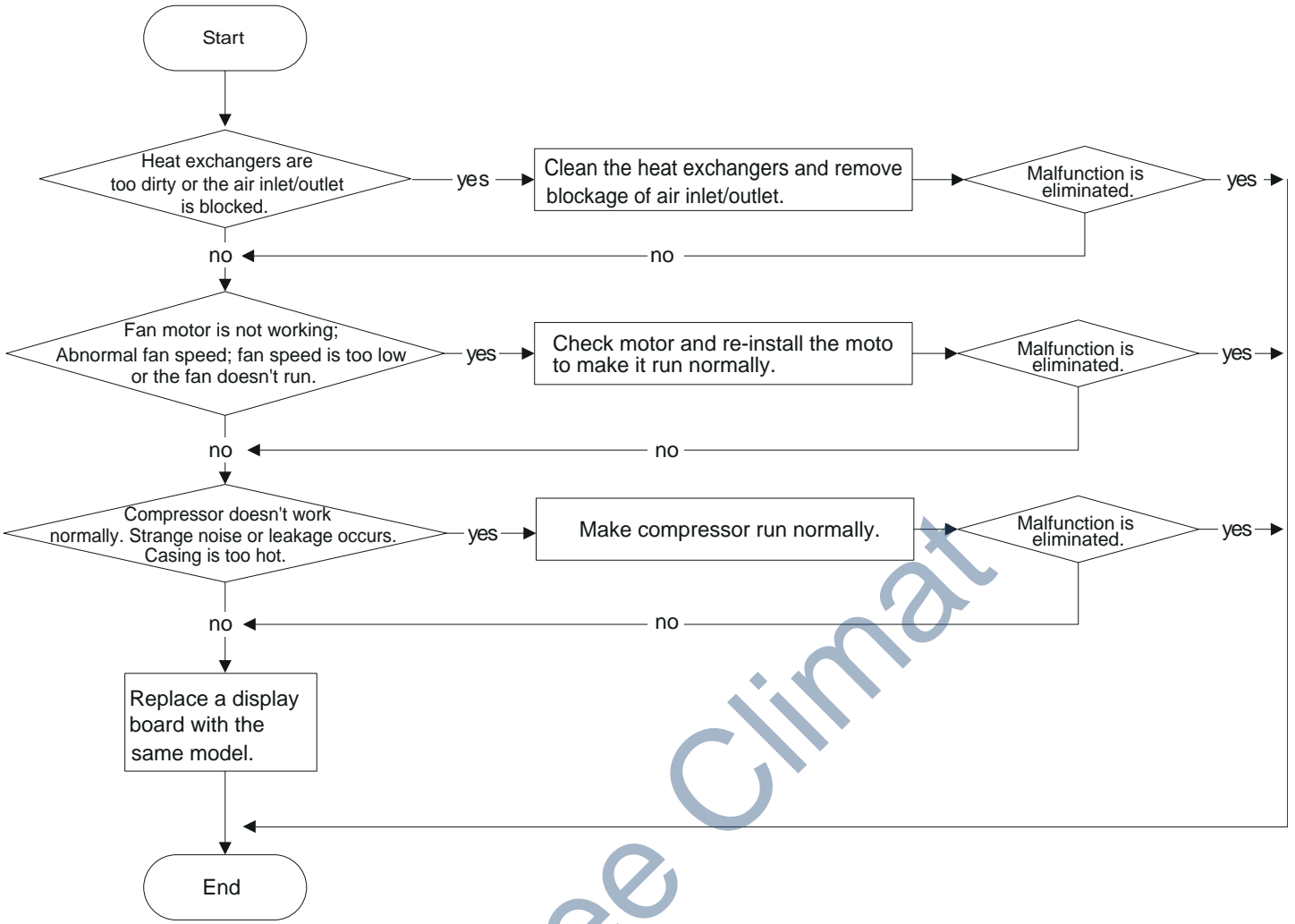

Gree Climat

9.6 Maintenance Method for Common Malfunction

1. The Unit Can't Start Up

Possible causes	Discriminating method (dehumidifier status)	Troubleshooting
No power supply, or poor connection for power plug	After energization, operation indicator isn't bright and the buzzer can't give out sound	Confirm whether it's due to power failure. If yes, wait for power recovery. If not, check power supply circuit and make sure the power plug is connected well.
Poor connection between wiring terminals	Power indicator is not on after the unit is energized	Check the circuit according to wiring diagram and connect wire properly; ensure each wiring terminal contact firmly
There is electric leakage in the unit	Circuit breaker jump off immediately after the unit is energized	Make sure the unit is properly grounded; Make sure the wiring is correct; Check if the insulating layer of wires inside the unit and power cord is in good condition; if the layer is broken, please replace it.
Placing position of water tank is not correct. Water is removed or the water is full.	Wall-full indicator flashes.	Make sure the water tank is placed correctly.

2. Poor Dehumidifying Effect

Possible causes	Discriminating method (dehumidifier status)	Troubleshooting
Filter is blocked	Check the filter to see if it's blocked	Clean the filter
Placing position of water tank is improper.	Check whether there are obstacles around the dehumidifier blocked the air outlet.	Make sure there are no obstacles around the dehumidifiers.
Refrigerant is leaking	Air outlet temperature is lower than normal temperature during dehumidifying period.	Find out the cause of leakage and solve the problem; charge refrigerant
Malfunction of capillary	Air outlet temperature is lower than normal temperature during dehumidifying period. If the refrigerant isn't leaking, some parts of capillary is blocked.	Replace capillary
Malfunction of fan	Fan can't operate.	Refer to point 3 of maintenance method for details
Malfunction of compressor	Compressor can't operate	Refer to point 4 of maintenance method for details

3. Fan Can't Operate

Possible causes	Discriminating method (dehumidifier status)	Troubleshooting
Wrong wire connection, or poor connection	Check the wiring status according to circuit diagram	Connect wires according to wiring diagram to make sure all wiring terminals are connected firmly
Needle stand of connection wire between mainboard and display board is loosened	Check if the needle stand is loosened	Reinsert the needle stand firmly
Fan capacitor is broken	Test the voltage between two ends of fan capacitor with universal meter and the value is 0	Replace fan capacitor
Power supply voltage is too low or too high	Test the power supply voltage with universal meter and the value is too high or too low	Apply voltage regulator
Fan is broken	The above situation is normal but the fan does not operate	Repair or replace the fan

4. Compressor Can't Operate

Possible causes	Discriminating method (dehumidifier status)	Troubleshooting
Wrong wire connection, or poor connection	Check the wiring status according to circuit diagram	Connect wires according to wiring diagram to make sure all wiring terminals are connected firmly
Compressor relay on the mainboard is broken or the compressor needle stand is loosened	Check if the relay is sucked in cooling mode	Replace the mainboard with the same model
Power voltage is a little low or high	After turning on the unit, dehumidifying effect is poor or compressor is turned on or off frequently. Use universal meter to measure the power supply voltage directly	The fluctuation of voltage is 10% rated power. If the power is too low or too high, you are suggested to equip wit voltage regulator.

5. Water Leakage

Possible causes	Discriminating method (dehumidifier status)	Troubleshooting
Drainage pipe hasnt been installed correctly.	Water is coming out from indoors.	Eliminate the blocking objects inside the drainage channel.

6. Abnormal Sounds and Vibration

Possible causes	Discriminating method (dehumidifier status)	Troubleshooting
There is abnormal sound in some parts when just turning on or turning off the unit	Theres the sound of "PAPA"	Normal phenomenon. Abnormal sound will disappear after a few minutes.
There is abnormal sound of refrigerant flowing when just turning on or turning off the unit	Water-running sound can be heard	Normal phenomenon. Abnormal sound will disappear after a few minutes.
There is touching sound of foreign objects or parts inside the unit	The unit gives out abnormal sound	Take out the foreign objects; adjust the position of each part inside the unit; tighten the connection screws; apply some damping gum on the touching parts
Abnormal shake of compressor	Outdoor unit gives out abnormal sound	Adjust the support foot mat of compressor, tighten the bolts
Abnormal sound inside the compressor	Abnormal sound inside the compressor	If add too much refrigerant during maintenance, please reduce refrigerant properly. Replace compressor for other circumstances.

NO.	Description	Part Code		Qty
		GDN16BE-K5EBA1A	GDN20BE-K5EBA1A	
	Product code	CK051037800	CK051037701	
1	Front Panel	200003060165T	200003060165T	1
2	Water Tank Sub-Assy	000094060005	000094060005	1
3	Water Tank	200103060004	200103060004	1
4	Partition Pole (PC board)	7671101601	7671101601	1
5	Buoy (magnet)	812360000001	812360000001	1
6	Water Tank Cover	200104060005	200104060005	1
7	Air Flue Assy	000011060082	000011060082	1
8	Centrifugal Fan	103003060026	103003060026	1
9	Fan Motor	1501605709	1501605709	1
10	Wire Clamp	26116069	26116069	1
11	Diversion Circle	200150060016	200150060016	1
12	Baffle Plate	200012060031	200012060031	1
13	Left Side Plate	200239060013	200239060013	1
14	Top Cover Assy	000097060238	000097060238	1
15	Detecting Plate	300018060176	300018060176	1
16	Display Board	300001060583	300001060583	1
17	Temperature Sensor	390000595	390000595	1
18	Coping	200106060032	200106060032	1
19	Membrane	60000606015901	60000606015901	1
20	Heat-exchange Equipment	011004060028P	011004060026P	1
21	Condenser Sub-Assy	010002060236P	010002060236P	1
22	Evaporator Sub-Assy	010001060332P	010001060323P	1
23	Capillary Sub-assy	030006060724	030006060681	1
24	Rear Plate Sub-Assy	209051060003	209051060003	1
25	Rear Plate	200245060009	200245060009	1
26	Latch	70811002	70811002	2
27	Front Grill Assy	000236060004	000236060004	1
28	Filter Sub-Assy	111001060161	111001060161	1
29	Front Grill	200226060016	200226060016	1
30	Electric Box Assy	10000206782101	10000206782101	1
31	Electric Box	012017060277	012017060277	1
32	fixed support (mainboard)	200115060013	200115060013	1
33	Main Board	300002061195	300002061195	1
34	Capacitor CBB61	3301074716	3301074716	1
35	Electric Box Cover	012020060213A	012020060213A	1
36	Right Side Plate	200239060012	200239060012	1
37	Cover of drainage hole	2224609703	2224609703	1
38	Inhalation Tube	035006061608	035006061608	1
39	Discharge Tube	035008061657	035008061657	1
40	Compressor and Fittings	009001060419	009001060419	1
41	Compressor Gasket	009012060011	009012060011	4
42	Power Cord	4002028636	4002028636	1
43	Chassis Assy	209058060212	209058060212	1
44	Chassis Sub-assy	209020060027	209020060027	1
45	Rubber Plug	76716059	76716059	4
46	Detecting Plate	300018060144	300018060144	1
47	Castor	24236554	24236554	4
48	Water Tray Assy	000069060229	000069060229	1
49	Water Tray 1	200063060012	200063060012	1
50	Rubber Plug	76716054	76716054	1
51	Supporting Strip	200175060020	200175060020	1
52	Proximity Switch	430015000003	430015000003	1
53	Water Tray 2	200063060013	200063060013	1
54	Adaptor sub-assy	26116155	26116155	1
55	Joint	26116154	26116154	1

Above data is subject to change without notice.

GDN20BE-K5EBA2A GDN24BE-K5EBA2A

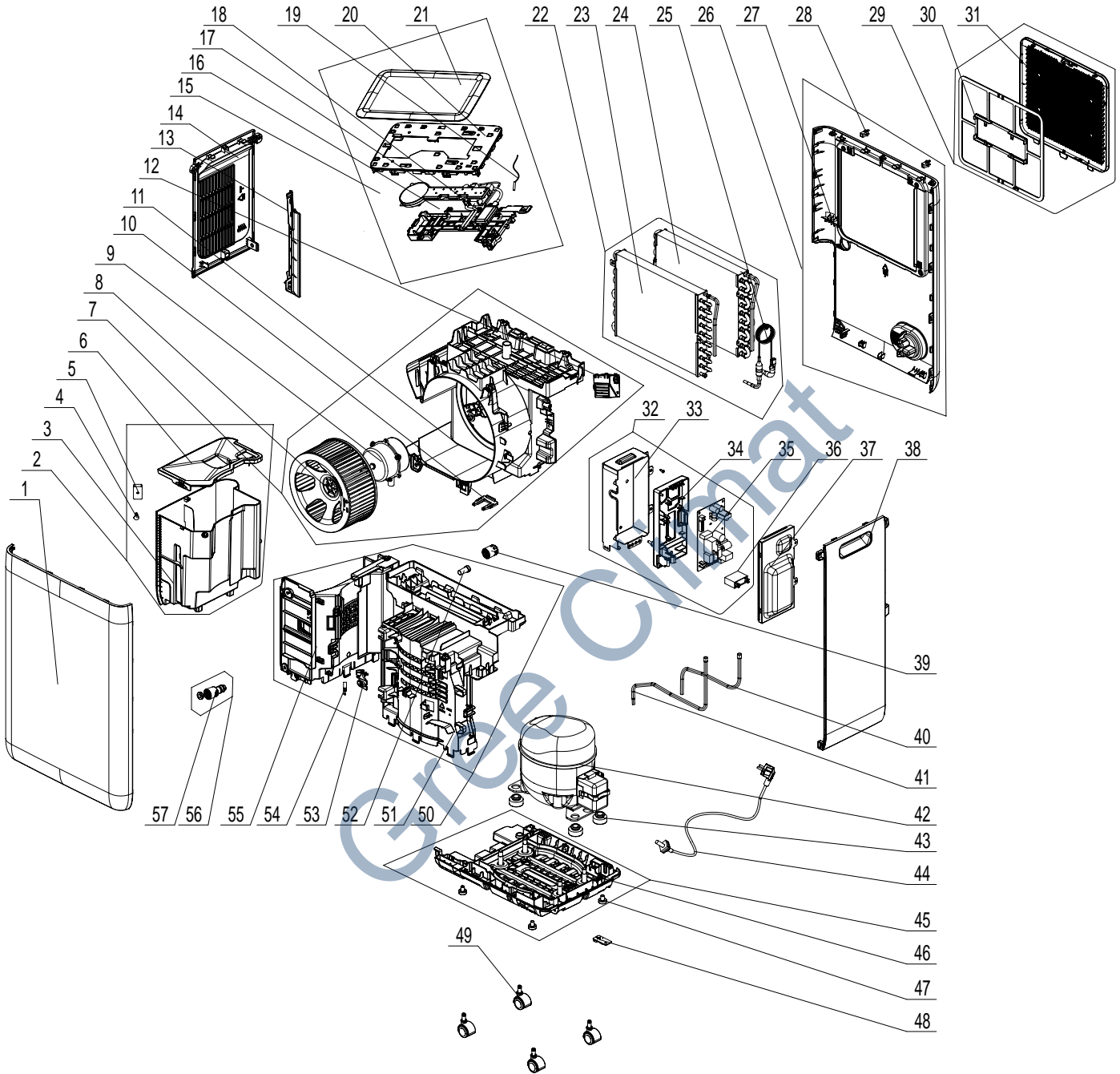

The component picture is only for reference; please refer to the actual product.

NO.	Description	Part Code		Qty
		GDN20BE-K5EBA2A	GDN24BE-K5EBA2A	
	Product code	CK051043000	CK051043100	
1	Front Panel	200003060165T	200003060165T	1
2	Water Tank Sub-Assy	0000940600005	0000940600005	1
3	Water Tank	2001030600004	2001030600004	1
4	Partition Pole (PC board)	7671101601	7671101601	1
5	Buoy (magnet)	812360000001	812360000001	1
6	Water Tank Cover	2001040600005	2001040600005	1
7	Air Flue Assy	000011060142	000011060141	1
8	Centrifugal Fan	103003060026	103003060026	1
9	Fan Motor	1501605709	1501605710	1
10	Wire Clamp	26116069	26116069	1
11	Diversion Circle	200150060016	200150060016	1
12	UV Germicidal Lamp	4302220000005	4302220000005	1
13	Baffle Plate	200012060031	200012060031	1
14	Left Side Plate	200239060013	200239060013	1
15	Top Cover Assy	00009706025304	00009706025304	1
16	Fixed Moubt(Display board)	200115060012	200115060012	1
17	Display Board	300001060848	300001060848	1
18	Detecting Plate	300018060176	300018060176	1
19	Temperature Sensor	390000595	390000595	1
20	Base Plate	200008060007	200008060007	1
21	Top Cover	200106060043S04	200106060043S04	1
22	Heat-exchange Equipment	011004060026P	011004060026P	1
23	Condenser Sub-Assy	010002060236P	010002060236P	1
24	Evaporator Sub-Assy	010001060323P	010001060323P	1
25	Capillary Sub-assy	030006060681	030006060681	1
26	Rear Plate Sub-Assy	209051060003	209051060003	1
27	Rear Plate	200245060009	200245060009	1
28	Latch	70811002	70811002	2
29	Front Grill Assy	000236060004	000236060004	1
30	Filter Sub-Assy	111001060161	111001060161	1
31	Front Grill	200226060016	200226060016	1
32	Electric Box Assy	10000206782101	10000206782103	1
33	Electric Box	012017060277	012017060277	1
34	Fixed Support (mainboard)	200115060013	200115060013	1
35	Main Board	300002061195	300002061195	1
36	Capacitor CBB61	3301074716	3301074701	1
37	Electric Box Cover	012020060213A	012020060213A	1
38	Right Side Plate	200239060012	200239060012	1
39	Cover of drainage hole	2224609703	2224609703	1
40	Inhalation Tube	035006061608	035006061608	1
41	Discharge Tube	035008061657	035008061657	1
42	Compressor and Fittings	009001060419	009001060419	1
43	Compressor Gasket	009012060011	009012060011	4
44	Power Cord	4002028636	4002028636	1
45	Chassis Assy	209058060212	209058060212	1
46	Chassis Sub-assy	209020060027	209020060027	1
47	Rubber Plug	76716059	76716059	4
48	Detecting Plate	300018060176	300018060176	1
49	Castor	24236554	24236554	4
50	Water Tray Assy	000069060229	000069060229	1
51	Water Tray 1	200063060012	200063060012	1
52	Rubber Plug	76716059	76716059	1
53	Supporting Strip	200175060020	200175060020	1
54	Proximity Switch	430015000003	430015000003	1
55	Water Tray 2	200063060013	200063060013	1
56	Adaptor sub-assy	26116155	26116155	1
57	Joint	26116154	26116154	1

Above data is subject to change without notice.

11. Removal Procedure

GDN16BE-K5EBA1A GDN20BE-K5EBA1A

Warning: disconnect power supply before removal; Prohibit disassembling and maintaining the refrigeration system pipeline and parts (include evaporator, condenser, compressor, capillary, etc.)

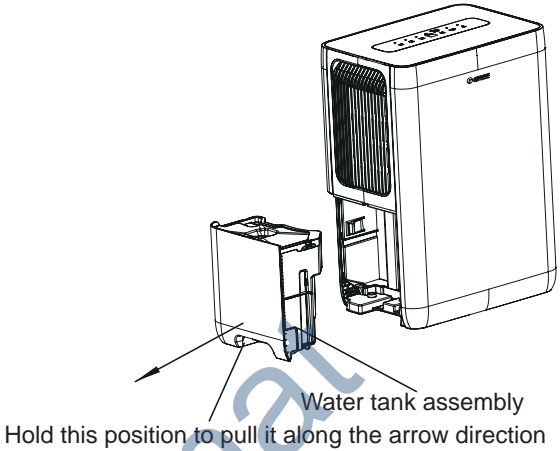
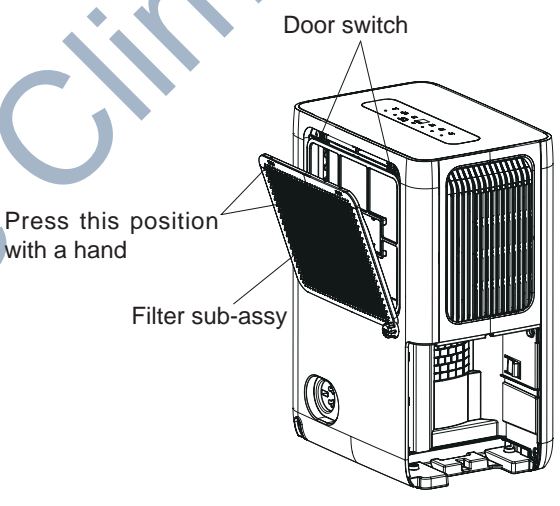
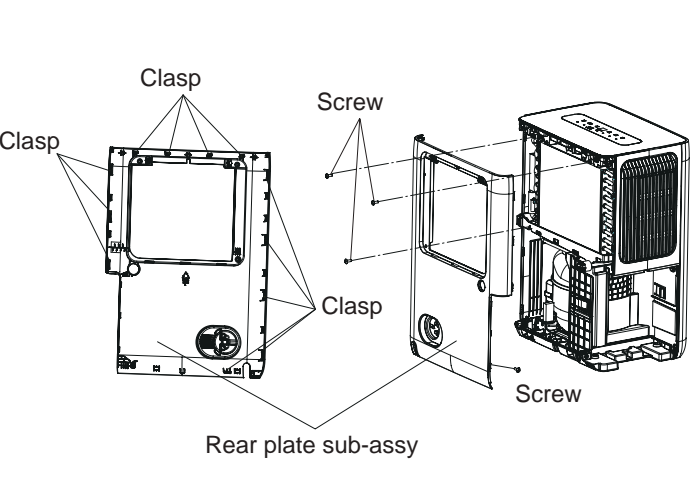
Step	Procedure
<p>1. Remove water tank sub-assy</p>	<p>Hold the hand-holding position at the bottom of the water tank, pull the water tank (along the arrow position) and then remove the water tank sub-assy.</p>  <p>Water tank assembly Hold this position to pull it along the arrow direction</p>
<p>2. Remove filter sub-assy</p>	<p>Press "PUSH" position with a hand to separate it from these 2 door switches on the rear plate, and then remove the filter sub-assy.</p>  <p>Door switch Press this position with a hand Filter sub-assy</p>
<p>3. Remove rear plate sub-assy</p>	<p>Remove 3 screws on the back of the case and 1 screw under the water tank, pull it rear plate sub-assy outwards to separate it from all clasps and then the rear plate sub-assy can be removed.</p>  <p>Clasp Screw Clasp Screw Rear plate sub-assy</p>

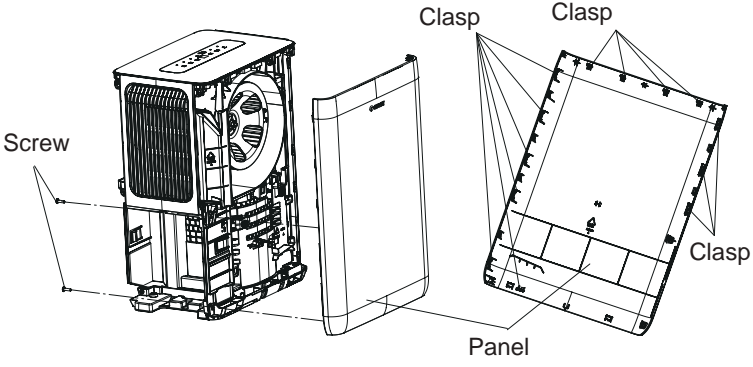
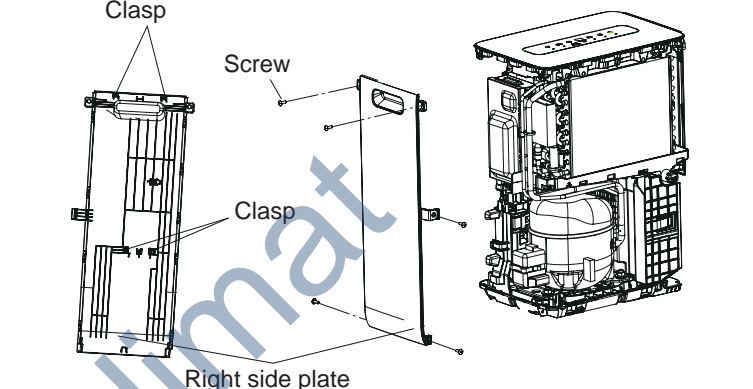
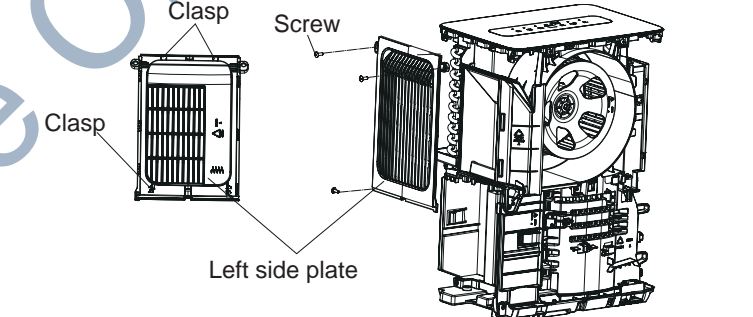
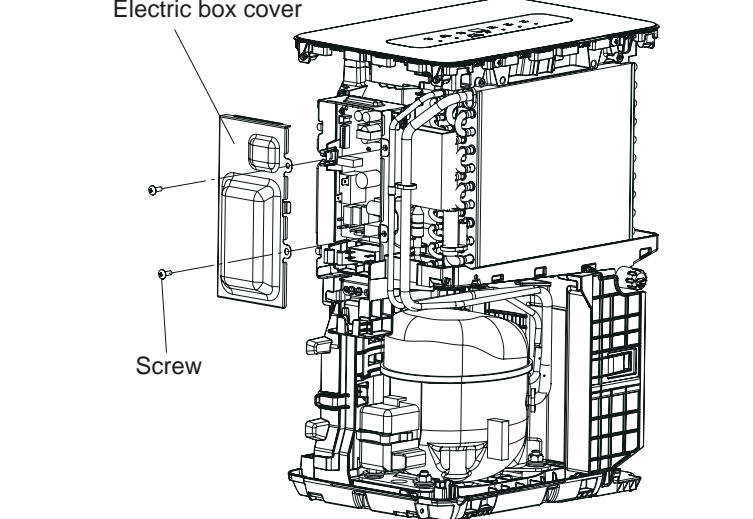
Step	Procedure
<p>4. Remove panel</p> <p>Remove 2 screws under the water tank, pull the panel outwards to make it come out of all clasps and then remove the panel.</p>	
<p>5. Remove right side plate</p> <p>Remove 5 screws used for fixing the right side plate and then pull the right side plate outwards to separate it from 4 clasps in the middle, and then the right side plate can be removed.</p>	
<p>6. Remove left side plate</p> <p>Remove 3 screws used for fixing the left side plate and then pull the left side plate outwards to separate it from 3 clasps in the middle, and then the left side plate can be removed.</p>	
<p>7. Remove electric box cover</p> <p>Remove 2 screws on the electric box cover and then remove the electric box cover.</p>	

Step	Procedure	Image
<p>8. Remove top cover sub-assy</p>	<p>Remove 4 screws used for fixing the top cover sub-assy, and take it outwards to separate these 2 clasps in front of the top cover sub-assy. Separate connection wires of discharge temperature sensor and display board to separate from all grooves, hold two sides of the top cover sub-assy, pull it upwards and then remove the top cover sub-assy.</p>	<p>The diagram illustrates the top cover sub-assembly being removed from the main unit. A separate view shows the sub-assembly with two clasps. The main view shows the sub-assembly being lifted away from the electric box cover.</p>
<p>9. Remove display sub-assy and detecting plate(WIFI)</p>	<p>Remove 4 screw used for fixing the display, separate the display sbu-assy from the clasps and then remove the display sub-assy. Remove 1 screw used for fixing the detecting plate(WIFI), separate the detecting plate(WIFI) from the Top Cover Assy and then remove the detecting plate(WIFI).</p>	<p>The diagram shows the internal components of the top cover. A display sub-assembly is being separated from the main cover. A detecting plate (WIFI) is also shown being removed from the assembly. Labels point to a screw, the detecting plate, and a clasp.</p>
<p>10. Remove Baffle Plate</p>	<p>Remove the screws under the baffle Plate, separate the baffle plate from the clasp and then remove the baffle plate.</p>	<p>The diagram shows the baffle plate being removed from the front of the unit. A clasp is shown holding the plate in place, and a screw is used to secure it. Labels identify the clasp, the baffle plate, and the screw.</p>

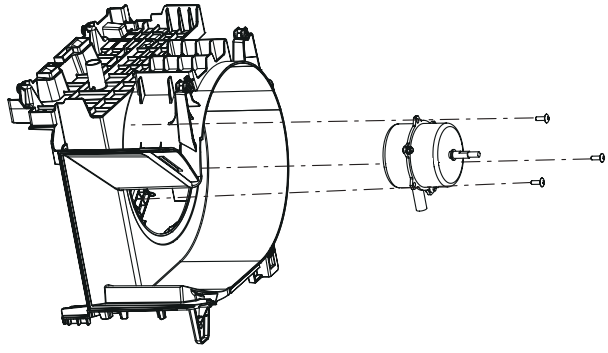
Step	Procedure
14. Remove motor	
Pull out the wire-pressing plate, remove 3 screws used for fixing the motor and then remove the motor.	

Gree Climat

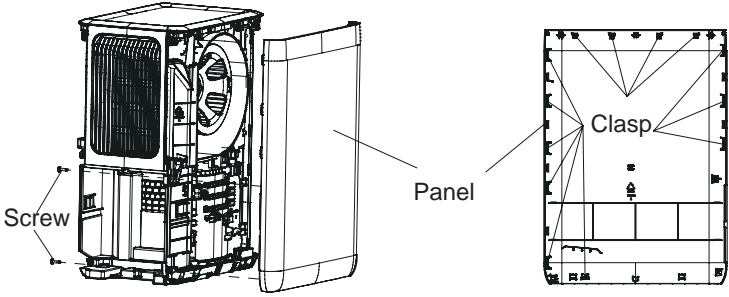
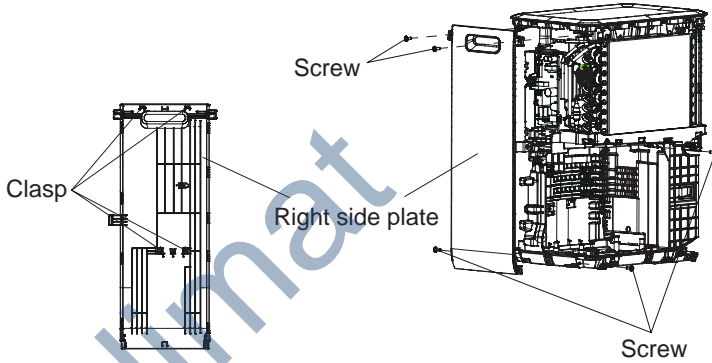
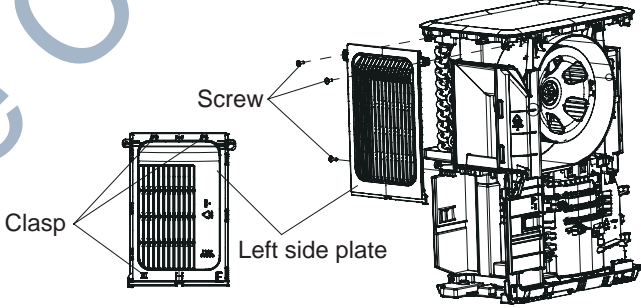
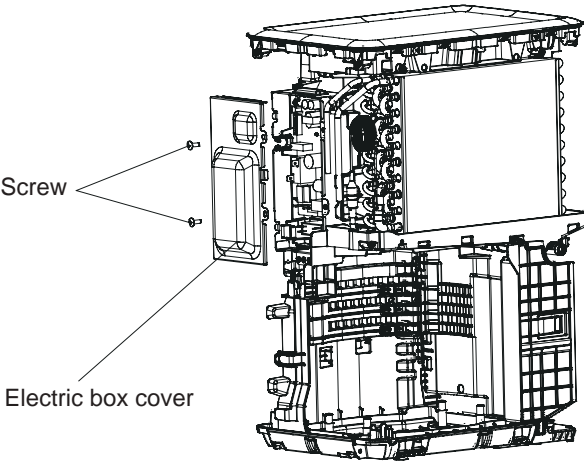
Step	Procedure
<p>4. Remove panel</p>	<p>Remove 2 screws under the water tank, pull the panel outwards to make it come out of all clasps and then remove the panel.</p> 
<p>5. Remove right side plate</p>	<p>Remove 5 screws used for fixing the right side plate and then pull the right side plate outwards to separate it from 4 clasps in the middle, and then the right side plate can be removed.</p> 
<p>6. Remove left side plate</p>	<p>Remove 3 screws used for fixing the left side plate and then pull the left side plate outwards to separate it from 3 clasps in the middle, and then the left side plate can be removed.</p> 
<p>7. Remove electric box cover</p>	<p>Remove 2 screws on the electric box cover and then remove the electric box cover.</p> 

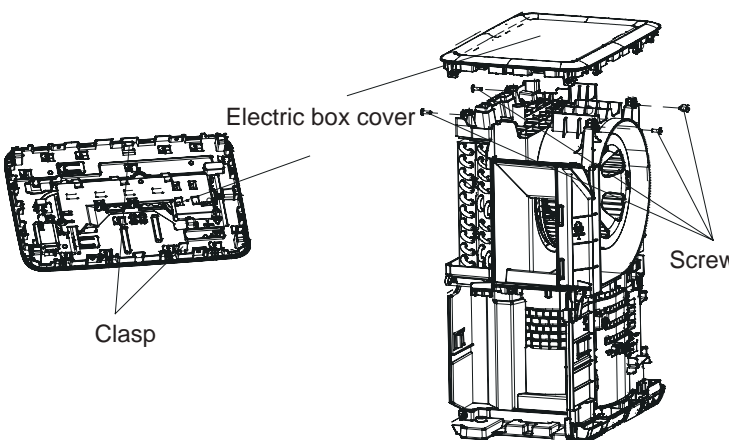
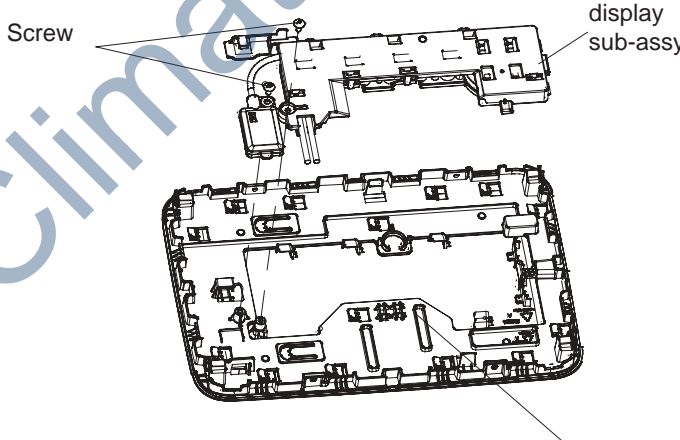
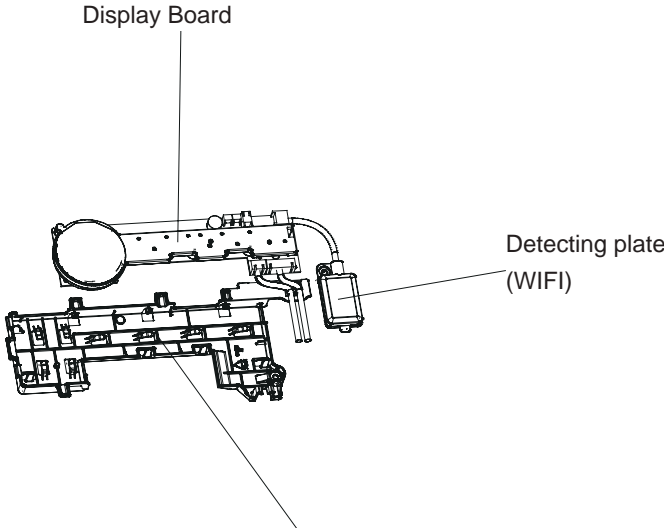
Step	Procedure
<p>8. Remove top cover sub-assy</p>	<p>Remove 4 screws used for fixing the top cover sub-assy, and take it outwards to separate these 2 clasps in front of the top cover sub-assy. Separate connection wires of discharge temperature sensor and display board to separate from all grooves, hold two sides of the top cover sub-assy, pull it upwards and then remove the top cover sub-assy.</p> 
<p>9. Remove display sub-assy</p>	<p>Remove 4 screw used for fixing the display sub-assy and detecting plate(WIFI), separate the display sbu-assy from the clasps and then remove the display sub-assy.</p> 
<p>10. Remove Fixed Mount(Display board), Display Board and detecting plate(WIFI)</p>	<p>Separate the Fixed Mount(Display board) from the clasps and then remove the Fixed Mount(Display board).</p> 

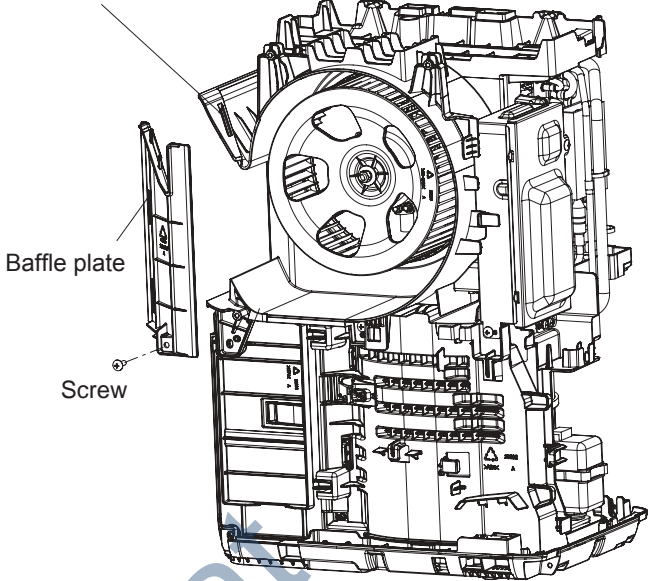
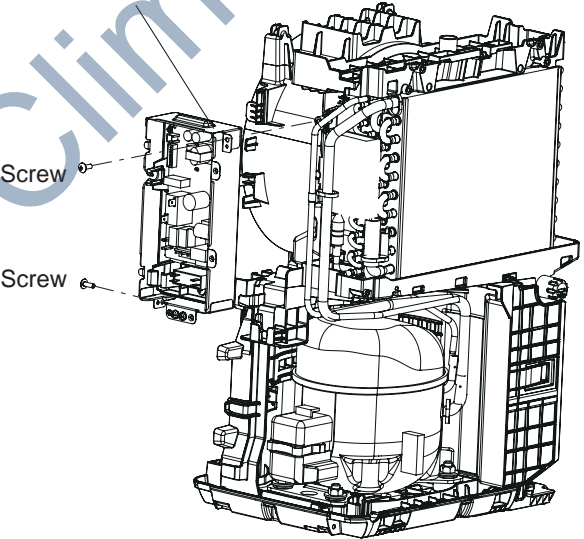
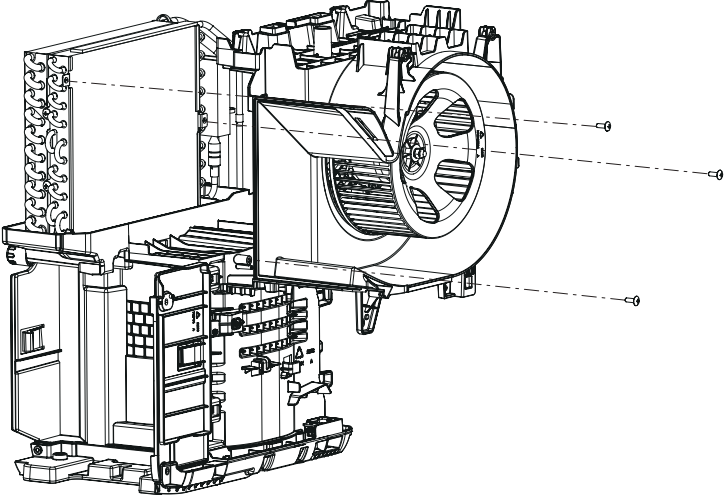
Step	Procedure	Procedure
<p>11. Remove Baffle Plate</p>	<p>Remove the screws under the baffle Plate, separate the baffle plate from the Diversion Circle and then remove the baffle plate.</p>	<p>Diversion Circle</p>  <p>Baffle plate</p> <p>Screw</p>
<p>12. Remove electric box</p>	<p>Pull out all wires connected with all electric elements inside the electric box, remove 2 screws connected with the water tray inside the electric box, and then remove the electric box.</p>	<p>Electric box</p>  <p>Screw</p> <p>Screw</p>
<p>13. Remove air duct</p>	<p>Remove 1 screw used for fixing the water tray and 2 screws used for fixing the evaporator and the condenser, pull the air duct backwards and then remove the air duct.</p>	

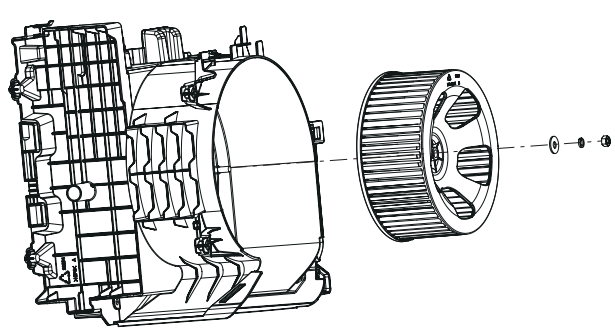
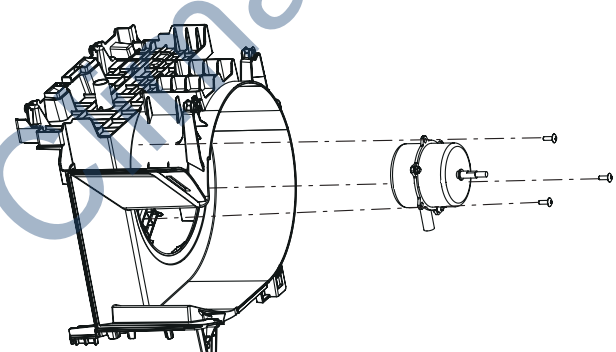
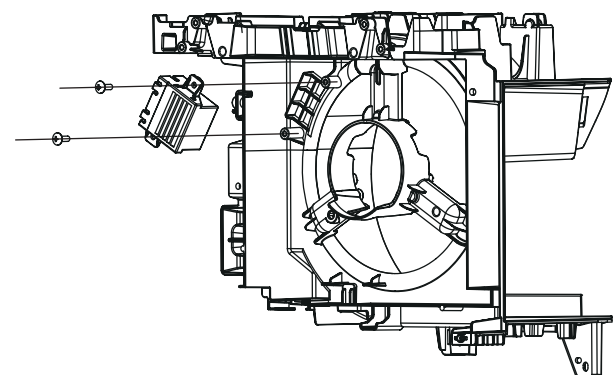
Step		Procedure
14. Remove centrifugal blade	<p>Remove nuts used for fixing the blades at the motor terminal and 2 washer; pull the blade along the motor shaft and then remove the blade sub-assy.</p>	
15. Remove motor	<p>Pull out the wire-pressing plate, remove 3 screws used for fixing the motor and then remove the motor.</p>	
16. UV Germicidal Lamp	<p>Remove 2 screw used for fixing the UV Germicidal Lamp and then remove the dUV Germicidal Lamp.</p>	

Appendix:

Appendix 1: Reference Sheet of Celsius and Fahrenheit

Conversion formula for Fahrenheit degree and Celsius degree: $T_f = T_c \times 1.8 + 32$

Set temperature

Fahrenheit display temperature (°F)	Fahrenheit (°F)	Celsius (°C)	Fahrenheit display temperature (°F)	Fahrenheit (°F)	Celsius (°C)	Fahrenheit display temperature (°F)	Fahrenheit (°F)	Celsius (°C)
61	60.8	16	69/70	69.8	21	78/79	78.8	26
62/63	62.6	17	71/72	71.6	22	80/81	80.6	27
64/65	64.4	18	73/74	73.4	23	82/83	82.4	28
66/67	66.2	19	75/76	75.2	24	84/85	84.2	29
68	68	20	77	77	25	86	86	30

Ambient temperature

Fahrenheit display temperature (°F)	Fahrenheit (°F)	Celsius (°C)	Fahrenheit display temperature (°F)	Fahrenheit (°F)	Celsius (°C)	Fahrenheit display temperature (°F)	Fahrenheit (°F)	Celsius (°C)
32/33	32	0	55/56	55.4	13	79/80	78.8	26
34/35	33.8	1	57/58	57.2	14	81	80.6	27
36	35.6	2	59/60	59	15	82/83	82.4	28
37/38	37.4	3	61/62	60.8	16	84/85	84.2	29
39/40	39.2	4	63	62.6	17	86/87	86	30
41/42	41	5	64/65	64.4	18	88/89	87.8	31
43/44	42.8	6	66/67	66.2	19	90	89.6	32
45	44.6	7	68/69	68	20	91/92	91.4	33
46/47	46.4	8	70/71	69.8	21	93/94	93.2	34
48/49	48.2	9	72	71.6	22	95/96	95	35
50/51	50	10	73/74	73.4	23	97/98	96.8	36
52/53	51.8	11	75/76	75.2	24	99	98.6	37
54	53.6	12	77/78	77	25			

GREE CLIMAT

Appendix 2: Resistance Table of Temperature Sensor

Resistance table of ambient temperature sensor (15K)

Temp.(°F)	Resistance(kΩ)	Temp.(°F)	Resistance(kΩ)	Temp.(°F)	Resistance(kΩ)	Temp.(°F)	Resistance(kΩ)
-2.2	138.1	68	18.75	138.2	3.848	208.4	1.071
-0.4	128.6	69.8	17.93	140	3.711	210.2	1.039
1.4	121.6	71.6	17.14	141.8	3.579	212	1.009
3.2	115	73.4	16.39	143.6	3.454	213.8	0.98
5	108.7	75.2	15.68	145.4	3.333	215.6	0.952
6.8	102.9	77	15	147.2	3.217	217.4	0.925
8.6	97.4	78.8	14.36	149	3.105	219.2	0.898
10.4	92.22	80.6	13.74	150.8	2.998	221	0.873
12.2	87.35	82.4	13.16	152.6	2.896	222.8	0.848
14	82.75	84.2	12.6	154.4	2.797	224.6	0.825
15.8	78.43	86	12.07	156.2	2.702	226.4	0.802
17.6	74.35	87.8	11.57	158	2.611	228.2	0.779
19.4	70.5	89.6	11.09	159.8	2.523	230	0.758
21.2	66.88	91.4	10.63	161.6	2.439	231.8	0.737
23	63.46	93.2	10.2	163.4	2.358	233.6	0.717
24.8	60.23	95	9.779	165.2	2.28	235.4	0.697
26.6	57.18	96.8	9.382	167	2.206	237.2	0.678
28.4	54.31	98.6	9.003	168.8	2.133	239	0.66
30.2	51.59	100.4	8.642	170.6	2.064	240.8	0.642
32	49.02	102.2	8.297	172.4	1.997	242.6	0.625
33.8	46.6	104	7.967	174.2	1.933	244.4	0.608
35.6	44.31	105.8	7.653	176	1.871	246.2	0.592
37.4	42.14	107.6	7.352	177.8	1.811	248	0.577
39.2	40.09	109.4	7.065	179.6	1.754	249.8	0.561
41	38.15	111.2	6.791	181.4	1.699	251.6	0.547
42.8	36.32	113	6.529	183.2	1.645	253.4	0.532
44.6	34.58	114.8	6.278	185	1.594	255.2	0.519
46.4	32.94	116.6	6.038	186.8	1.544	257	0.505
48.2	31.38	118.4	5.809	188.6	1.497	258.8	0.492
50	29.9	120.2	5.589	190.4	1.451	260.6	0.48
51.8	28.51	122	5.379	192.2	1.408	262.4	0.467
53.6	27.18	123.8	5.197	194	1.363	264.2	0.456
55.4	25.92	125.6	4.986	195.8	1.322	266	0.444
57.2	24.73	127.4	4.802	197.6	1.282	267.8	0.433
59	23.6	129.2	4.625	199.4	1.244	269.6	0.422
60.8	22.53	131	4.456	201.2	1.207	271.4	0.412
62.6	21.51	132.8	4.294	203	1.171	273.2	0.401
64.4	20.54	134.6	4.139	204.8	1.136	275	0.391
66.2	19.63	136.4	3.99	206.6	1.103	276.8	0.382

Resistance Table of Tube Temperature Sensors (20K)

Temp.(°F)	Resistance(kΩ)	Temp.(°F)	Resistance(kΩ)	Temp.(°F)	Resistance(kΩ)	Temp.(°F)	Resistance(kΩ)
-2.2	181.4	68	25.01	138.2	5.13	208.4	1.427
-0.4	171.4	69.8	23.9	140	4.948	210.2	1.386
1.4	162.1	71.6	22.85	141.8	4.773	212	1.346
3.2	153.3	73.4	21.85	143.6	4.605	213.8	1.307
5	145	75.2	20.9	145.4	4.443	215.6	1.269
6.8	137.2	77	20	147.2	4.289	217.4	1.233
8.6	129.9	78.8	19.14	149	4.14	219.2	1.198
10.4	123	80.6	18.13	150.8	3.998	221	1.164
12.2	116.5	82.4	17.55	152.6	3.861	222.8	1.131
14	110.3	84.2	16.8	154.4	3.729	224.6	1.099
15.8	104.6	86	16.1	156.2	3.603	226.4	1.069
17.6	99.13	87.8	15.43	158	3.481	228.2	1.039
19.4	94	89.6	14.79	159.8	3.364	230	1.01
21.2	89.17	91.4	14.18	161.6	3.252	231.8	0.983
23	84.61	93.2	13.59	163.4	3.144	233.6	0.956
24.8	80.31	95	13.04	165.2	3.04	235.4	0.93
26.6	76.24	96.8	12.51	167	2.94	237.2	0.904
28.4	72.41	98.6	12	168.8	2.844	239	0.88
30.2	68.79	100.4	11.52	170.6	2.752	240.8	0.856
32	65.37	102.2	11.06	172.4	2.663	242.6	0.833
33.8	62.13	104	10.62	174.2	2.577	244.4	0.811
35.6	59.08	105.8	10.2	176	2.495	246.2	0.77
37.4	56.19	107.6	9.803	177.8	2.415	248	0.769
39.2	53.46	109.4	9.42	179.6	2.339	249.8	0.746
41	50.87	111.2	9.054	181.4	2.265	251.6	0.729
42.8	48.42	113	8.705	183.2	2.194	253.4	0.71
44.6	46.11	114.8	8.37	185	2.125	255.2	0.692
46.4	43.92	116.6	8.051	186.8	2.059	257	0.674
48.2	41.84	118.4	7.745	188.6	1.996	258.8	0.658
50	39.87	120.2	7.453	190.4	1.934	260.6	0.64
51.8	38.01	122	7.173	192.2	1.875	262.4	0.623
53.6	36.24	123.8	6.905	194	1.818	264.2	0.607
55.4	34.57	125.6	6.648	195.8	1.736	266	0.592
57.2	32.98	127.4	6.403	197.6	1.71	267.8	0.577
59	31.47	129.2	6.167	199.4	1.658	269.6	0.563
60.8	30.04	131	5.942	201.2	1.609	271.4	0.549
62.6	28.68	132.8	5.726	203	1.561	273.2	0.535
64.4	27.39	134.6	5.519	204.8	1.515	275	0.521
66.2	26.17	136.4	5.32	206.6	1.47	276.8	0.509

Resistance table of ambient temperature sensor (100K)

Temp(°F)	Resistance(kΩ)	Temp(°F)	Resistance(kΩ)	Temp(°F)	Resistance(kΩ)	Temp(°F)	Resistance(kΩ)
-4.0	925.998	64.4	136.845	132.8	28.638	201.2	7.918
-2.2	876.141	66.2	130.752	134.6	27.600	203.0	7.676
-0.4	829.261	68.0	124.961	136.4	26.606	204.8	7.443
1.4	785.155	69.8	119.456	138.2	25.652	206.6	7.218
3.2	743.636	71.6	114.221	140.0	24.737	208.4	7.000
5.0	704.532	73.4	109.242	141.8	23.858	210.2	6.790
6.8	667.688	75.2	104.506	143.6	23.016	212.0	6.587
8.6	632.956	77.0	100.000	145.4	22.207	213.8	6.391
10.4	600.201	78.8	95.711	147.2	21.430	215.6	6.201
12.2	569.300	80.6	91.629	149.0	20.684	217.4	6.018
14.0	540.135	82.4	87.742	150.8	19.967	219.2	5.842
15.8	512.601	84.2	84.041	152.6	19.279	221.0	5.671
17.6	486.596	86.0	80.515	154.4	18.617	222.8	5.505
19.4	462.029	87.8	77.155	156.2	17.981	224.6	5.346
21.2	438.812	89.6	73.954	158.0	17.370	226.4	5.191
23.0	416.865	91.4	70.902	159.8	16.782	228.2	5.042
24.8	396.114	93.2	67.993	161.6	16.217	230.0	4.898
26.6	376.487	95.0	65.218	163.4	15.673	231.8	4.758
28.4	357.918	96.8	62.572	165.2	15.150	233.6	4.624
30.2	340.348	98.6	60.017	167.0	14.646	235.4	4.493
32.0	323.717	100.4	57.637	168.8	14.141	237.2	4.367
33.8	307.972	102.2	55.337	170.6	13.695	239.0	4.245
35.6	293.062	104.0	53.141	172.4	13.245	240.8	4.127
37.4	278.941	105.8	51.043	174.2	12.813	242.6	4.012
39.2	265.562	107.6	49.040	176.0	12.396	244.4	3.902
41.0	252.886	109.4	47.126	177.8	11.995	246.2	3.795
42.8	240.871	111.2	45.296	179.6	11.608	248.0	3.691
44.6	229.482	113.0	43.548	181.4	11.235	249.8	3.591
46.4	218.684	114.8	41.876	183.2	10.876	251.6	3.494
48.2	208.443	116.6	40.276	185.0	10.530	253.4	3.400
50.0	198.729	118.4	38.747	186.8	10.196	255.2	3.309
51.8	189.514	120.2	37.283	188.6	9.874	257.0	3.221
53.6	180.769	122.0	35.882	190.4	9.564	258.8	3.136
55.4	172.469	123.8	34.541	192.2	9.265	260.6	3.053
57.2	164.590	125.6	33.257	194.0	8.976	262.4	2.973
59.0	157.109	127.4	32.027	195.8	8.697	264.2	2.896
60.8	150.005	129.2	30.849	197.6	8.428	266.0	2.821
62.6	143.256	131.0	29.720	199.4	8.169	267.8	2.748

Appendix 3: Resistance Value Table of Humidity Sensor

HIS-06 temperature and humidity characteristic 5°C ~ 14°C

Unit: KΩ

Relative humidity	Temperature (°C)									
	5°C	6°C	7°C	8°C	9°C	10°C	11°C	12°C	13°C	14°C
90	5.35	4.92	4.55	4.23	3.95	3.70	3.47	3.25	3.05	2.87
89	5.80	5.33	4.93	4.58	4.27	4.00	3.74	3.51	3.29	3.09
88	6.29	5.77	5.33	4.95	4.62	4.32	4.03	3.78	3.54	3.32
87	6.82	6.25	5.77	5.36	4.99	4.66	4.35	4.08	3.82	3.58
86	7.40	6.78	6.25	5.80	5.40	5.04	4.70	4.40	4.11	3.85
85	8.03	7.35	6.78	6.28	5.84	5.45	5.09	4.75	4.45	4.16
84	8.71	7.97	7.35	6.81	6.33	5.91	5.50	5.14	4.80	4.49
83	9.44	8.65	7.97	7.39	6.87	6.41	5.96	5.56	5.19	4.84
82	10.25	9.39	8.65	8.02	7.46	6.96	6.47	6.03	5.62	5.24
81	11.13	10.19	9.40	8.71	8.10	7.56	7.03	6.54	6.09	5.68
80	12.09	11.07	10.21	9.46	8.80	8.21	7.62	7.08	6.59	6.13
79	13.14	12.03	11.09	10.28	9.57	8.93	8.28	7.70	7.16	6.66
78	14.27	13.07	12.05	11.17	10.40	9.70	8.99	8.35	7.75	7.20
77	15.50	14.20	13.10	12.14	11.30	10.55	9.78	9.07	8.43	7.83
76	16.84	15.43	14.24	13.21	12.30	11.48	10.64	9.87	9.16	8.51
75	18.31	16.78	15.49	14.37	13.38	12.50	11.58	10.75	9.98	9.26
74	19.91	18.25	16.85	15.64	14.57	13.62	12.62	11.72	10.89	10.12
73	21.67	19.87	18.35	17.04	15.88	14.84	13.71	12.67	11.72	10.84
72	23.61	21.66	20.00	18.57	17.31	16.18	14.98	13.90	12.89	11.96
71	25.78	23.64	21.84	20.27	18.89	17.66	16.35	15.16	14.06	13.05
70	28.15	25.82	23.85	22.15	20.65	19.30	17.91	16.63	15.46	14.37
69	30.78	28.24	26.10	24.24	22.60	21.13	19.60	18.19	16.91	15.71
68	33.69	30.92	28.58	26.55	24.76	23.16	21.48	19.94	18.53	17.22
67	36.90	33.88	31.33	29.11	27.16	25.42	23.56	21.86	20.29	18.85
66	40.45	37.16	34.37	31.96	29.84	27.93	25.83	23.92	22.15	20.52
65	44.38	40.78	37.74	35.11	32.78	30.70	28.42	26.34	24.42	22.65
64	48.75	44.81	41.48	38.59	36.05	33.77	31.24	28.93	26.80	24.83
63	53.64	49.31	45.65	42.48	39.68	37.17	34.34	31.74	29.36	27.15
62	59.14	54.36	50.32	46.82	43.73	40.97	37.83	34.96	32.32	29.87
61	65.31	60.02	55.55	51.68	48.26	45.20	41.70	38.51	35.58	32.86
60	72.27	66.40	61.43	57.13	53.33	49.94	46.07	42.53	39.28	36.27
59	80.13	73.58	68.04	63.25	59.01	55.23	50.94	47.03	43.43	40.10
58	88.92	81.61	75.43	70.08	65.36	61.14	56.40	52.08	48.11	44.43
57	98.86	90.68	83.77	77.78	72.50	67.78	62.49	57.67	53.23	49.12
56	112.59	102.79	94.50	87.33	81.00	75.33	69.42	64.03	59.07	54.48
55	122.69	112.51	103.91	96.45	89.88	84.00	77.42	71.41	65.88	60.76
54	137.09	125.76	116.19	107.89	100.57	94.03	86.69	79.99	73.82	68.11
53	153.46	140.88	130.25	121.03	112.91	105.64	97.26	89.61	82.58	76.06
52	172.19	158.19	146.35	136.10	127.05	118.96	109.52	100.90	92.97	85.63
51	193.69	178.04	164.81	153.36	143.25	134.21	123.35	113.43	104.31	95.86
50	218.48	200.85	185.94	173.02	161.63	151.44	139.14	127.90	117.57	108.01
49	247.23	227.16	210.19	195.49	182.52	170.92	156.84	143.98	132.15	121.20
48	278.74	256.20	237.15	220.64	206.08	193.06	177.34	163.00	149.80	137.58
47	315.50	289.95	268.35	249.64	233.14	218.37	200.56	184.30	169.34	155.49
46	357.93	328.94	304.43	283.20	264.47	247.72	227.57	209.18	192.25	176.59
45	406.44	373.72	346.05	322.08	300.94	282.03	259.22	238.40	219.24	201.51
44	463.66	426.44	394.96	367.70	343.66	322.14	296.25	272.62	250.87	230.74
43	531.25	488.59	452.53	421.28	393.73	369.08	339.44	312.38	287.50	264.45
42	611.22	562.01	520.40	484.35	452.55	424.11	390.24	359.31	330.86	304.52
41	707.78	650.29	601.68	559.58	522.44	489.21	450.38	414.92	382.31	352.11
40	823.98	756.22	698.93	649.30	605.53	566.37	521.46	480.46	442.74	407.81
39	962.72	882.62	814.90	756.23	704.48	658.19	604.79	556.03	511.18	469.66

38	1128.50	1033.61	953.39	883.90	822.61	767.78	704.83	647.37	594.51	545.56
37	1325.87	1213.40	1118.31	1035.94	963.29	898.30	823.48	755.17	692.34	634.16
36	1563.51	1430.14	1317.38	1219.71	1133.55	1056.48	967.04	885.39	810.28	740.74
35	1855.67	1695.83	1560.69	1443.63	1340.37	1248.00	1140.34	1042.06	951.64	867.93
34	2213.60	2020.33	1856.92	1715.37	1590.51	1478.82	1349.81	1232.04	1123.70	1023.39
33	2665.63	2426.92	2225.10	2050.27	1896.06	1758.12	1605.77	1466.69	1338.74	1220.28
32	3230.73	2933.36	2681.95	2464.17	2272.06	2100.23	1916.82	1749.39	1595.37	1452.76
31	3962.78	3585.59	3266.69	2990.44	2746.77	2528.80	2308.12	2106.66	1921.33	1749.74
30	4915.40	4431.65	4022.65	3668.35	3355.84	3076.30	2801.20	2550.06	2319.03	2105.13
29	6180.16	5548.66	5014.73	4552.22	4144.26	3779.32	3431.59	3114.13	2822.10	2551.72
28	7874.08	7035.10	6325.74	5711.27	5169.27	4684.43	4243.82	3841.57	3471.54	3128.95
27	10162.49	9029.08	8070.80	7240.70	6508.50	5853.53	5293.25	4781.75	4311.22	3875.57
26	13243.42	11702.63	10399.92	9271.46	8276.08	7385.69	6658.01	5993.68	5382.56	4816.75
25	17366.01	15270.67	13499.09	11964.48	10610.86	9400.00	8447.52	7577.98	6778.07	6037.48
24	22845.46	20023.30	17637.20	15570.26	13747.10	12116.22	10866.57	9725.72	8676.25	7704.59
23	30130.06	26367.98	23187.18	20431.85	18001.48	15827.43	14156.73	12631.50	11228.43	9929.38
22	39673.45	34712.87	30518.76	26885.65	23681.03	20814.39	18624.92	16626.08	14787.33	13084.91
21	51880.00	45447.42	40008.75	35297.56	31142.00	27424.72	24504.12	21837.82	19385.06	17114.16
20	68057.37	59623.21	52492.24	46315.10	40866.49	35992.53	32084.71	28517.14	25235.30	22196.79

HIS-06 temperature and humidity characteristic 15°C ~24°C

Unit:KΩ

Relative humidity	Temperature (°C)									
	15°C	16°C	17°C	18°C	19°C	20°C	21°C	22°C	23°C	24°C
90	2.70	2.56	2.43	2.31	2.19	2.08	1.99	1.91	1.83	1.75
89	2.91	2.76	2.61	2.48	2.35	2.23	2.13	2.04	1.95	1.86
88	3.12	2.96	2.80	2.66	2.52	2.39	2.28	2.18	2.08	1.98
87	3.36	3.18	3.01	2.85	2.70	2.56	2.44	2.33	2.22	2.12
86	3.61	3.42	3.23	3.06	2.90	2.75	2.62	2.50	2.38	2.27
85	3.90	3.69	3.49	3.30	3.12	2.95	2.81	2.67	2.54	2.42
84	4.20	3.97	3.76	3.55	3.36	3.18	3.03	2.88	2.74	2.61
83	4.52	4.28	4.05	3.83	3.63	3.43	3.26	3.10	2.94	2.79
82	4.89	4.63	4.38	4.14	3.92	3.71	3.52	3.33	3.16	2.99
81	5.29	5.00	4.73	4.48	4.24	4.01	3.80	3.60	3.42	3.23
80	5.70	5.39	5.10	4.83	4.57	4.33	4.10	3.88	3.68	3.48
79	6.19	5.85	5.53	5.22	4.94	4.67	4.41	4.17	3.94	3.72
78	6.69	6.32	5.96	5.63	5.32	5.02	4.75	4.49	4.24	4.01
77	7.27	6.85	6.46	6.09	5.74	5.41	5.11	4.83	4.56	4.31
76	7.90	7.44	7.00	6.59	6.20	5.83	5.51	5.21	4.92	4.65
75	8.60	8.08	7.60	7.14	6.71	6.30	5.95	5.62	5.30	4.99
74	9.40	8.82	8.28	7.77	7.29	6.83	6.45	6.09	5.74	5.41
73	10.02	9.44	8.89	8.38	7.89	7.43	7.01	6.60	6.21	5.84
72	11.10	10.43	9.79	9.19	8.63	8.09	7.62	7.17	6.74	6.33
71	12.10	11.36	10.67	10.02	9.40	8.82	8.31	7.82	7.36	6.92
70	13.36	12.52	11.72	10.98	10.27	9.60	9.03	8.49	7.97	7.48
69	14.60	13.67	12.79	11.97	11.19	10.45	9.82	9.23	8.66	8.11
68	16.00	14.96	13.99	13.07	12.20	11.37	10.68	10.02	9.39	8.78
67	17.50	16.35	15.27	14.26	13.30	12.39	11.61	10.86	10.15	9.47
66	19.00	17.76	16.60	15.51	14.47	13.49	12.64	11.83	11.05	10.31
65	21.00	19.59	18.26	17.01	15.82	14.70	13.76	12.86	12.01	11.19
64	23.00	21.43	19.96	18.57	17.25	16.00	14.98	14.00	13.06	12.16
63	25.10	23.38	21.77	20.24	18.80	17.44	16.31	15.24	14.22	13.24
62	27.60	25.66	23.84	22.13	20.51	18.97	17.73	16.55	15.42	14.34
61	30.33	28.17	26.14	24.23	22.42	20.71	19.37	18.10	16.88	15.72
60	33.47	31.05	28.78	26.64	24.62	22.70	21.24	19.84	18.50	17.23
59	37.00	34.31	31.77	29.39	27.13	24.99	23.37	21.83	20.36	18.95
58	41.00	38.00	35.18	32.52	30.00	27.61	25.82	24.11	22.47	20.90
57	45.30	41.99	38.88	35.95	33.18	30.54	28.59	26.72	24.94	23.24

56	50.20	46.55	43.12	39.89	36.83	33.93	31.76	29.69	27.71	25.82
55	56.00	51.92	48.08	44.47	41.05	37.80	35.35	33.02	30.79	28.65
54	62.80	58.20	53.88	49.80	45.95	42.29	39.51	36.87	34.34	31.92
53	70.00	64.95	60.21	55.74	51.51	47.50	44.33	41.31	38.42	35.65
52	78.80	73.12	67.79	62.76	58.00	53.49	49.86	46.40	43.10	39.94
51	88.00	81.79	75.97	70.47	65.27	60.34	56.11	52.08	48.23	44.54
50	99.10	92.12	85.57	79.39	73.55	68.00	63.15	58.52	54.10	49.86
49	111.00	103.28	96.04	89.20	82.74	76.61	70.94	65.54	60.38	55.44
48	126.20	117.27	108.88	100.97	93.48	86.38	79.89	73.71	67.79	62.13
47	142.60	132.48	122.97	114.00	105.52	97.48	90.16	83.18	76.51	70.12
46	162.00	150.38	139.46	129.16	119.43	110.19	101.62	93.45	85.64	78.17
45	185.00	171.49	158.81	146.85	135.53	124.80	115.00	105.66	96.74	88.20
44	212.00	196.23	181.41	167.45	154.23	141.70	130.18	119.19	108.69	98.64
43	243.00	224.65	207.41	191.15	175.78	161.19	148.03	135.48	123.49	112.01
42	280.00	258.38	238.08	218.93	200.82	183.64	168.64	154.32	140.65	127.56
41	324.00	298.37	274.29	251.59	230.12	209.75	192.53	176.11	160.43	145.41
40	375.30	344.95	316.43	289.55	264.12	240.00	220.30	201.52	183.57	166.39
39	431.00	395.97	363.07	332.05	302.71	274.87	251.94	230.08	209.19	189.19
38	500.00	458.51	419.54	382.80	348.04	315.07	289.04	264.21	240.49	217.78
37	580.00	531.11	485.18	441.88	400.92	362.06	332.09	303.52	276.21	250.07
36	676.00	618.14	563.79	512.55	464.08	418.09	383.52	350.57	319.07	288.92
35	790.00	721.80	657.74	597.34	540.20	486.00	445.77	407.41	370.75	335.66
34	930.00	848.96	772.84	701.08	633.19	568.78	521.38	476.19	433.01	391.66
33	1110.00	1011.10	918.19	830.60	747.75	669.14	613.58	560.59	509.97	461.49
32	1320.00	1201.45	1090.09	985.09	885.78	791.56	725.62	662.75	602.68	545.17
31	1590.00	1444.80	1308.40	1179.80	1058.15	942.75	863.43	787.81	715.55	646.36
30	1906.00	1731.91	1568.38	1414.20	1268.36	1130.00	1034.60	943.64	856.73	773.51
29	2300.00	2089.81	1892.37	1706.22	1530.13	1363.08	1244.55	1131.54	1023.56	920.17
28	2810.00	2550.31	2306.37	2076.38	1858.82	1652.43	1505.84	1366.07	1232.52	1104.65
27	3470.00	3144.23	2838.22	2549.70	2276.79	2017.87	1836.86	1664.27	1499.35	1341.45
26	4290.00	3885.50	3505.53	3147.28	2808.41	2486.92	2253.64	2031.21	1818.67	1615.18
25	5348.00	4843.01	4368.65	3921.40	3498.35	3097.00	2802.48	2521.66	2253.33	1996.42
24	6800.00	6152.28	5543.84	4970.19	4427.56	3912.77	3538.27	3181.20	2840.01	2513.33
23	8720.00	7888.61	7107.64	6371.32	5674.82	5014.05	4529.95	4068.38	3627.32	3205.04
22	11500.00	10371.38	9311.21	8311.65	7366.14	6469.15	5839.63	5239.39	4665.85	4116.71
21	15000.00	13512.80	12115.79	10798.65	9552.74	8370.76	7546.29	6760.17	6009.01	5289.82
20	19368.00	17441.37	15631.58	13925.26	12311.23	10780.00	9716.41	8702.31	7733.29	6805.52

HIS-06 temperature and humidity characteristic 25°C ~ 34°C

Unit:KQ

Relative humidity	Temperature (°C)									
	25°C	26°C	27°C	28°C	29°C	30°C	31°C	32°C	33°C	34°C
90	1.68	1.62	1.57	1.52	1.47	1.42	1.37	1.33	1.28	1.24
89	1.78	1.72	1.66	1.61	1.55	1.50	1.45	1.40	1.36	1.31
88	1.89	1.83	1.76	1.70	1.65	1.59	1.54	1.49	1.44	1.39
87	2.02	1.95	1.88	1.81	1.74	1.68	1.63	1.57	1.52	1.47
86	2.16	2.08	2.00	1.93	1.85	1.78	1.72	1.66	1.61	1.55
85	2.30	2.21	2.13	2.05	1.97	1.89	1.82	1.76	1.70	1.64
84	2.48	2.38	2.28	2.19	2.10	2.01	1.94	1.87	1.80	1.73
83	2.65	2.54	2.43	2.33	2.24	2.14	2.06	1.98	1.91	1.83
82	2.83	2.71	2.60	2.49	2.38	2.28	2.19	2.11	2.02	1.94
81	3.06	2.93	2.80	2.67	2.55	2.44	2.34	2.24	2.15	2.06
80	3.28	3.14	3.00	2.86	2.73	2.60	2.49	2.38	2.28	2.18
79	3.51	3.35	3.20	3.05	2.91	2.78	2.65	2.54	2.42	2.31
78	3.78	3.61	3.44	3.28	3.12	2.97	2.83	2.70	2.57	2.45
77	4.06	3.87	3.69	3.51	3.34	3.17	3.03	2.88	2.74	2.61
76	4.38	4.17	3.97	3.77	3.58	3.40	3.23	3.07	2.92	2.77
75	4.70	4.47	4.25	4.04	3.84	3.64	3.46	3.28	3.11	2.94
74	5.09	4.83	4.59	4.35	4.12	3.90	3.70	3.51	3.32	3.14

73	5.49	5.21	4.94	4.68	4.43	4.19	3.97	3.75	3.54	3.34
72	5.93	5.62	5.33	5.04	4.77	4.50	4.26	4.02	3.80	3.57
71	6.49	6.13	5.79	5.46	5.14	4.84	4.57	4.32	4.07	3.83
70	7.00	6.61	6.24	5.88	5.53	5.20	4.91	4.63	4.35	4.09
69	7.59	7.16	6.75	6.35	5.96	5.59	5.27	4.97	4.67	4.38
68	8.20	7.73	7.28	6.84	6.42	6.01	5.67	5.34	5.01	4.70
67	8.82	8.32	7.83	7.36	6.91	6.47	6.10	5.74	5.38	5.04
66	9.60	9.03	8.49	7.96	7.46	6.97	6.57	6.18	5.80	5.43
65	10.40	9.78	9.18	8.61	8.06	7.52	7.08	6.65	6.24	5.84
64	11.30	10.62	9.96	9.33	8.72	8.13	7.65	7.19	6.74	6.30
63	12.30	11.55	10.82	10.12	9.45	8.80	8.27	7.75	7.26	6.78
62	13.30	12.49	11.71	10.96	10.23	9.53	8.96	8.41	7.87	7.35
61	14.60	13.69	12.81	11.97	11.15	10.36	9.73	9.12	8.53	7.96
60	16.00	14.99	14.02	13.08	12.17	11.30	10.61	9.94	9.29	8.66
59	17.60	16.48	15.40	14.35	13.35	12.38	11.61	10.87	10.15	9.46
58	19.40	18.15	16.95	15.79	14.68	13.60	12.75	11.93	11.13	10.36
57	21.60	20.18	18.81	17.49	16.22	14.99	14.05	13.14	12.26	11.41
56	24.00	22.40	20.86	19.37	17.94	16.55	15.50	14.48	13.50	12.54
55	26.60	24.81	23.10	21.44	19.84	18.30	17.13	16.00	14.90	13.83
54	29.60	27.59	25.66	23.81	22.01	20.28	18.96	17.69	16.46	15.26
53	33.00	30.74	28.57	26.48	24.46	22.52	21.04	19.62	18.24	16.90
52	36.90	34.35	31.90	29.53	27.25	25.05	23.38	21.77	20.21	18.69
51	41.00	38.18	35.47	32.86	30.34	27.90	26.03	24.22	22.46	20.76
50	45.80	42.62	39.55	36.60	33.75	31.00	28.91	26.89	24.93	23.03
49	50.70	47.20	43.83	40.59	37.45	34.43	32.08	29.81	27.61	25.47
48	56.70	52.72	48.90	45.21	41.66	38.22	35.62	33.10	30.67	28.30
47	64.00	59.37	54.91	50.61	46.46	42.46	39.57	36.78	34.07	31.45
46	71.00	65.89	60.97	56.22	51.65	47.23	43.99	40.85	37.81	34.86
45	80.00	74.13	68.48	63.03	57.78	52.70	49.02	45.46	42.00	38.65
44	89.00	82.54	76.32	70.33	64.54	58.96	54.75	50.69	46.74	42.92
43	101.00	93.48	86.25	79.28	72.55	66.06	61.28	56.65	52.17	47.82
42	115.00	106.23	97.79	89.66	81.81	74.23	68.69	63.33	58.14	53.10
41	131.00	120.81	111.01	101.56	92.44	83.64	77.33	71.23	65.31	59.57
40	149.90	138.01	126.56	115.53	104.88	94.60	87.37	80.37	73.58	66.99
39	170.00	156.52	143.54	131.04	118.97	107.32	99.08	91.11	83.38	75.88
38	196.00	180.09	164.79	150.04	135.81	122.06	112.71	103.65	94.88	86.37
37	225.00	206.61	188.92	171.87	155.41	139.52	128.86	118.54	108.53	98.82
36	260.00	238.50	217.80	197.86	178.62	160.04	147.90	136.16	124.77	113.73
35	302.00	276.83	252.61	229.27	206.76	185.00	170.96	157.37	144.19	131.41
34	352.00	322.66	294.42	267.21	240.96	215.59	199.30	183.53	168.24	153.40
33	415.00	380.13	346.58	314.24	283.04	252.90	233.57	214.84	196.70	179.09
32	490.00	448.82	409.19	371.01	334.16	298.57	275.69	253.53	232.06	211.23
31	580.00	531.32	484.48	439.35	395.79	353.72	326.76	300.66	275.37	250.83
30	693.69	634.81	578.16	523.57	470.89	420.00	387.67	356.36	326.02	296.58
29	821.00	751.60	684.82	620.48	558.38	498.40	459.39	421.61	385.00	349.49
28	982.00	898.01	817.20	739.32	664.18	591.58	544.87	499.65	455.82	413.29
27	1190.00	1085.85	985.63	889.06	795.87	705.85	649.51	594.96	542.09	490.80
26	1420.00	1297.43	1179.49	1065.83	956.17	850.22	781.68	715.32	651.00	588.59
25	1750.00	1597.27	1450.30	1308.67	1172.02	1040.00	954.91	872.53	792.68	715.22
24	2200.00	2005.83	1818.99	1638.94	1465.21	1297.38	1189.66	1085.37	984.29	886.22
23	2800.00	2551.47	2312.32	2081.87	1859.50	1644.68	1506.06	1371.84	1241.75	1115.55
22	3590.00	3270.74	2963.54	2667.51	2381.86	2105.90	1925.97	1751.75	1582.89	1419.07
21	4600.00	4191.56	3798.54	3419.81	3054.38	2701.33	2467.06	2240.24	2020.39	1807.10
20	5915.63	5385.23	4874.84	4383.03	3908.47	3450.00	3152.84	2865.12	2586.25	2315.70

HIS-06 Characteristic of temperature and humidity 35°C ~ 45°C

Unit:KΩ

Relative humidity	Temperature (°C)										
	35°C	36°C	37°C	38°C	39°C	40°C	41°C	42°C	43°C	44°C	45°C
90	1.20	1.17	1.14	1.11	1.08	1.05	1.02	1.00	0.98	0.95	0.93
89	1.27	1.23	1.20	1.16	1.13	1.10	1.07	1.05	1.02	1.00	0.97
88	1.34	1.30	1.26	1.22	1.19	1.15	1.12	1.09	1.07	1.04	1.02
87	1.42	1.37	1.33	1.29	1.25	1.21	1.18	1.15	1.12	1.09	1.06
86	1.50	1.45	1.40	1.36	1.31	1.27	1.24	1.20	1.17	1.14	1.11
85	1.58	1.53	1.48	1.43	1.38	1.33	1.29	1.26	1.23	1.19	1.16
84	1.67	1.61	1.56	1.50	1.45	1.40	1.36	1.32	1.29	1.25	1.21
83	1.76	1.70	1.64	1.58	1.52	1.47	1.43	1.39	1.35	1.31	1.27
82	1.86	1.79	1.73	1.66	1.60	1.54	1.50	1.45	1.41	1.37	1.33
81	1.97	1.90	1.82	1.75	1.69	1.62	1.57	1.53	1.48	1.44	1.40
80	2.08	2.00	1.93	1.85	1.78	1.71	1.66	1.61	1.56	1.51	1.46
79	2.20	2.12	2.03	1.95	1.88	1.80	1.74	1.69	1.64	1.59	1.54
78	2.33	2.24	2.15	2.07	1.98	1.90	1.84	1.78	1.72	1.67	1.61
77	2.48	2.38	2.28	2.18	2.09	2.00	1.94	1.87	1.81	1.75	1.69
76	2.62	2.51	2.41	2.31	2.21	2.12	2.05	1.98	1.91	1.84	1.78
75	2.78	2.67	2.56	2.45	2.34	2.24	2.16	2.09	2.01	1.94	1.87
74	2.96	2.84	2.71	2.60	2.48	2.37	2.29	2.20	2.12	2.04	1.97
73	3.14	3.01	2.88	2.75	2.63	2.51	2.42	2.33	2.24	2.15	2.07
72	3.36	3.21	3.06	2.92	2.78	2.65	2.55	2.46	2.36	2.27	2.18
71	3.60	3.44	3.28	3.12	2.97	2.82	2.71	2.61	2.50	2.40	2.30
70	3.83	3.65	3.48	3.32	3.16	3.00	2.88	2.77	2.65	2.54	2.43
69	4.10	3.91	3.73	3.55	3.37	3.20	3.07	2.94	2.82	2.70	2.58
68	4.40	4.19	3.99	3.79	3.60	3.41	3.27	3.13	2.99	2.86	2.73
67	4.71	4.49	4.27	4.06	3.85	3.65	3.49	3.34	3.19	3.05	2.90
66	5.08	4.83	4.59	4.36	4.13	3.91	3.74	3.57	3.41	3.25	3.09
65	5.45	5.19	4.93	4.68	4.44	4.20	4.01	3.83	3.65	3.47	3.30
64	5.88	5.59	5.31	5.04	4.78	4.52	4.31	4.11	3.91	3.72	3.53
63	6.31	6.00	5.70	5.41	5.13	4.85	4.63	4.41	4.20	4.00	3.80
62	6.84	6.50	6.17	5.84	5.53	5.22	4.98	4.75	4.52	4.30	4.09
61	7.40	7.03	6.66	6.31	5.97	5.63	5.37	5.12	4.88	4.64	4.41
60	8.05	7.64	7.24	6.86	6.48	6.11	5.83	5.55	5.28	5.01	4.76
59	8.78	8.33	7.89	7.46	7.05	6.64	6.33	6.02	5.72	5.43	5.14
58	9.61	9.10	8.61	8.13	7.66	7.20	6.86	6.52	6.19	5.87	5.56
57	10.58	10.00	9.43	8.88	8.34	7.82	7.44	7.08	6.72	6.36	6.02
56	11.61	10.96	10.33	9.71	9.11	8.53	8.11	7.70	7.30	6.91	6.53
55	12.80	12.07	11.36	10.68	10.00	9.35	8.88	8.42	7.97	7.53	7.10
54	14.10	13.29	12.50	11.73	10.98	10.25	9.72	9.21	8.70	8.21	7.73
53	15.60	14.68	13.78	12.90	12.05	11.22	10.63	10.06	9.50	8.96	8.42
52	17.22	16.18	15.18	14.20	13.24	12.31	11.66	11.02	10.40	9.79	9.19
51	19.10	17.93	16.79	15.68	14.59	13.54	12.81	12.10	11.40	10.72	10.05
50	21.18	19.87	18.60	17.36	16.15	14.97	14.14	13.33	12.54	11.77	11.01
49	23.40	21.97	20.57	19.21	17.89	16.60	15.65	14.73	13.82	12.94	12.08
48	26.00	24.35	22.75	21.20	19.68	18.20	17.17	16.16	15.18	14.21	13.27
47	28.90	27.06	25.28	23.54	21.85	20.20	19.03	17.88	16.77	15.68	14.61
46	32.00	29.95	27.96	26.03	24.14	22.30	21.00	19.74	18.50	17.29	16.11
45	35.40	33.16	30.99	28.87	26.81	24.80	23.33	21.90	20.50	19.14	17.80
44	39.20	36.71	34.29	31.93	29.64	27.40	25.79	24.21	22.67	21.17	19.70

43	43.60	40.77	38.02	35.35	32.74	30.20	28.45	26.73	25.06	23.43	21.83
42	48.20	45.06	42.00	39.02	36.13	33.30	31.40	29.55	27.74	25.97	24.25
41	54.00	50.43	46.97	43.59	40.30	37.10	34.98	32.92	30.90	28.93	27.00
40	60.60	56.63	52.78	49.02	45.36	41.80	39.36	36.98	34.66	32.39	30.17
39	68.60	64.04	59.61	55.30	51.10	47.00	44.23	41.53	38.89	36.31	33.78
38	78.10	72.70	67.45	62.33	57.35	52.50	49.44	46.45	43.54	40.69	37.90
37	89.40	82.99	76.75	70.68	64.76	59.00	55.58	52.24	48.98	45.80	42.68
36	103.00	95.43	88.06	80.89	73.91	67.10	63.17	59.33	55.59	51.93	48.35
35	119.00	110.35	101.94	93.75	85.77	78.00	73.18	68.47	63.88	59.39	55.00
34	139.00	129.32	119.90	110.73	101.80	93.10	86.80	80.66	74.66	68.80	63.07
33	162.00	149.97	138.28	126.90	115.81	105.00	98.24	91.63	85.19	78.89	72.73
32	191.00	176.44	162.29	148.50	135.08	122.00	114.10	106.40	98.87	91.52	84.34
31	227.00	209.28	192.04	175.27	158.93	143.00	133.62	124.46	115.52	106.79	98.25
30	268.00	247.75	228.05	208.88	190.20	172.00	160.04	148.37	136.97	125.83	114.95
29	315.00	291.16	267.97	245.41	223.43	202.00	187.96	174.26	160.88	147.81	135.03
28	372.00	342.25	313.32	285.16	257.73	231.00	215.94	201.25	186.90	172.88	159.17
27	441.00	404.50	369.01	334.45	300.80	268.00	251.39	235.18	219.35	203.88	188.76
26	528.00	484.54	442.27	401.13	361.06	322.00	301.66	281.81	262.43	243.49	224.98
25	640.00	590.21	541.79	494.65	448.75	404.00	375.91	348.49	321.72	295.57	270.00
24	791.00	735.73	681.97	629.64	578.68	529.00	486.67	445.36	405.02	365.60	327.08
23	993.00	926.97	862.74	800.23	739.35	680.00	621.22	563.85	507.84	453.11	399.61
22	1260.00	1171.18	1084.80	1000.72	918.82	839.00	766.05	694.86	625.34	557.42	491.03
21	1600.00	1476.79	1356.97	1240.33	1126.73	1016.00	929.53	845.14	762.74	682.23	603.53
20	2053.00	1880.43	1712.58	1549.22	1390.09	1235.00	1131.26	1030.03	931.17	834.59	740.18

Gree Climat



JF00304224

Gree Climat



GREE ELECTRIC APPLIANCES, INC. OF ZHUHAI

Add: West Jinji Rd, Qianshan, Zhuhai, Guangdong, China, 519070

Tel: (+86-756) 8522219

Fax: (+86-756) 8669426

E-mail: global@cn.gree.com www.gree.com

For product improvement, specifications and appearance in this manual are subject to change without prior notice.